

ZIEH-ABEGG GEARLESS MACHINES

CODE	CAPACITY	V(m/s)	CALCULATION	MODEL	P (kw)	Torque Nm	RPM	IN(A)	DRIVE(A)	PULLEY (MM)	SUSPENSION	ROPING	MAX - H (m)	COOLING (FAN BLOWER)
	(ظرفیت)	سرعت		(مدل)	(توان)			(آمپر)		(قطر فلکه)		(تعداد شیار)		
610	6 PERSON 450kg	1.0	f5792030	SM 200 . 15D-20	3.1	250	120	12.2	17	320	2:1	4*8 mm	30	----
614		1.0	f5792031	SM 200 . 15D-20	4.4	250	168	14.8	17	320	2:1	4*8 mm	30	----
616		1.6	f5792032	SM 200 . 15D-20	5/0	250	192	16.5	17	320	2:1	4*8 mm	30	----
810	8 PERSON 600kg	1.0	f5792033	SM 200 . 23D-20	4.8	380	120	13.8	17	320	2:1	6*8 mm	30	----
816		1.6	f5792034	SM 200 . 23D-20	7.6	380	192	20.7	23	320	2:1	6*8 mm	30	----
1010	10 PERSON 750kg	1.0	f5792035	SM 200 . 30D-20	6/0	475	120	16.4	17	320	2:1	6*8 mm	30	----
1016		1.6	f5792036	SM 200 . 30D-20	9.6	475	192	24.4	23	320	2:1	6*8 mm	30	----
1310	13 PERSON 1000kg	1.0	f5792037	SM 200 . 40E-20	7.5	600	120	19.3	23	320	2:1	7*8 mm	30	----
1316		1.6	f5792038	SM 200 . 40E-20	12.1	600	192	28.9	32	320	2:1	7*8 mm	30	----
1610	16 PERSON 1200kg	1.0	f5792039	SM 200 . 45E-20	8.9	710	120	23.3	23	320	2:1	8*8 mm	30	----
1616		1.6	f5792040	SM 200 . 45E-20	14.3	710	192	30.6	32	320	2:1	8*8 mm	30	----
2110	21 PERSON 1600kg	1.0	f5792041	SM 210 . 60B-20	10.7	850	120	31.5	32	320	2:1	10*8 mm	30	----
2116		1.6	f5792042	SM 210 . 60B-20	17.1	850	192	43.2	50	320	2:1	10*8 mm	30	----

STATIC LOAD (kg)	GROOVE				
	TYPE	γ	β	DsC	SHAVE WIDTH
1855	U	30	95	17	74
1855	U	30	95	17	74
1855	U	30	100	17	74
2850	U	30	95	17	110
2850	U	30	100	17	110
2850	U	30	95	17	110
2850	U	30	100	17	110
3600	U	30	95	17	122
3600	U	30	100	17	122
3600	U	30	100	14	122
3600	U	30	100	14	122
4500	U	30	100	14	150
4500	U	30	100	14	150

Movement by Perfection

Drive Technology

for elevators
2018 Edition

The Royal League in ventilation, control and drive technology

ZIEHL-ABEGG Brand Products for Elevator Technology



ZAtop - The Flexible One

Complete series for elevators up to 6,500 kg payload - everything from one single source! The gearless elevator machine of the ZAtop series, designed as an internal rotor is the BEST solution for elevators with and without machine room.



ZAsyn - The Slim One

Complete series for elevators up to 2,500 kg payload - everything from one single source! The gearless elevator machine of the ZAsyn series, designed as an external rotor, stands out as an extremely slim elevator machine for elevators with and without machine room.



ZAdisc - The Flat One

Complete series for elevators up to 1,125 kg payload - everything from one single source! The gearless elevator machine of the ZAdisc series, designed as a disc rotor, is the space-saving miracle par excellence for elevators without a machine room.



ZAlift - The Perfect Choice

With the ZAlift calculation software, you can accurately calculate the machine that fits to your elevator and get helpful information for the installation, operation and final inspection.



ZAdyn - For Proper Control

With the frequency inverter from the ZAdyn series, you comfortably and exactly control the speed of your elevator machines.



EVAC - The Bodyguard

The evacuation units from the EVAC series make laborious, delayed rescue of trapped people by external personnel superfluous.



ZApad - The Optimal Control







If you want external activation, the ZApad operating terminal is the perfect add-on for ZAdyn4C frequency inverter, ZAreC4C recuperation units and EVAC 3C evacuation units.



ZAmon - The Optimiser

If transparency and intelligent control are required, ZAmon is the software at your side. ZAmon provides all options needed to selectively control the ZAdyn frequency inverters, to backup and manage the data and to diagnose weak points - the optimiser for your elevator system.

Contents

The ZIEHL-ABEGG Company	Page 4	Information
Gearless elevator machines ZAtop	 Page 12	ZAtop
Gearless elevator machines ZAsyn	 Page 36	ZAsyn
Gearless elevator machines ZAdisc	 Page 44	ZAdisc
Motors VFD	 Page 50	VFD
System components	 Page 54	System components
Control technology	 Page 72	Control technology
System components control technology	 Page 90	System components control technology
General notes	Page 119	Appendix



ZAvblue

ZIEHL-ABEGG

Die Königsklasse

*der Lufttechnik,
Regeltechnik und Antriebstechnik*

**Mehr
Volumen
bei kleinerer
Baugröße**



Welcome to the world of ZIEHL-ABEGG

Top technology “Made by ZIEHL-ABEGG”

A pioneering spirit and the courage of innovation were the driving forces behind Emil Ziehl’s development of his first external rotor motor over a hundred years ago. With this he laid the corner stone for the success story of ZIEHL-ABEGG in 1910. Today, the family company ZIEHL-ABEGG, with its headquarters in Künzelsau, develops, produces and sells high quality, high-tech components: Fans, special electric motors and their perfectly adapted, state-of-the-art control technology. Still today, Emil Ziehl’s pioneering spirit is the motivator for making good even better and finding new, revolutionary solutions. ZIEHL-ABEGG is based in Southern Germany but is at home all over the world. At the world-wide production and sales sites, thousands of employees develop, produce and sell technical, economical and ecological progress.

Welcome to the world of ventilation, control and drive technology.

Your contact into the world of ZIEHL-ABEGG

Would you like to learn more about the company ZIEHL-ABEGG, its products and applications? Your current direct contact partners can always be found at www.ziehl-abegg.com



- Information
- ZAtop
- ZAsyn
- ZAdisc
- VFD
- System components motors
- Control technology
- System components control technology
- Appendix

Reliability Output Drive comfort

Elevator technology from ZIEHL-ABEGG

Millions of people ride elevators day for day all over the world. They ride quickly, safely and comfortably up to their offices, apartments or hotel rooms and back down again. They have good reason to trust this technology because many elevator manufacturers put their trust in the decisive contribution that ZIEHL-ABEGG makes to reliability and drive comfort. It is the drive and control engineering, the “heart” and “soul” of the elevator. One of the reasons for this trust is ZIEHL-ABEGG’s ability to adapt the motor and control engineering to the manufacturer’s specific requirements regardless of how far up or down the elevator is to travel and how much space is available. Another good reason is the ZIEHL-ABEGG know-how based on their 100 years of experience. It is the visions of the elevator manufacturers that become reality in the drive and control systems made by ZIEHL-ABEGG.



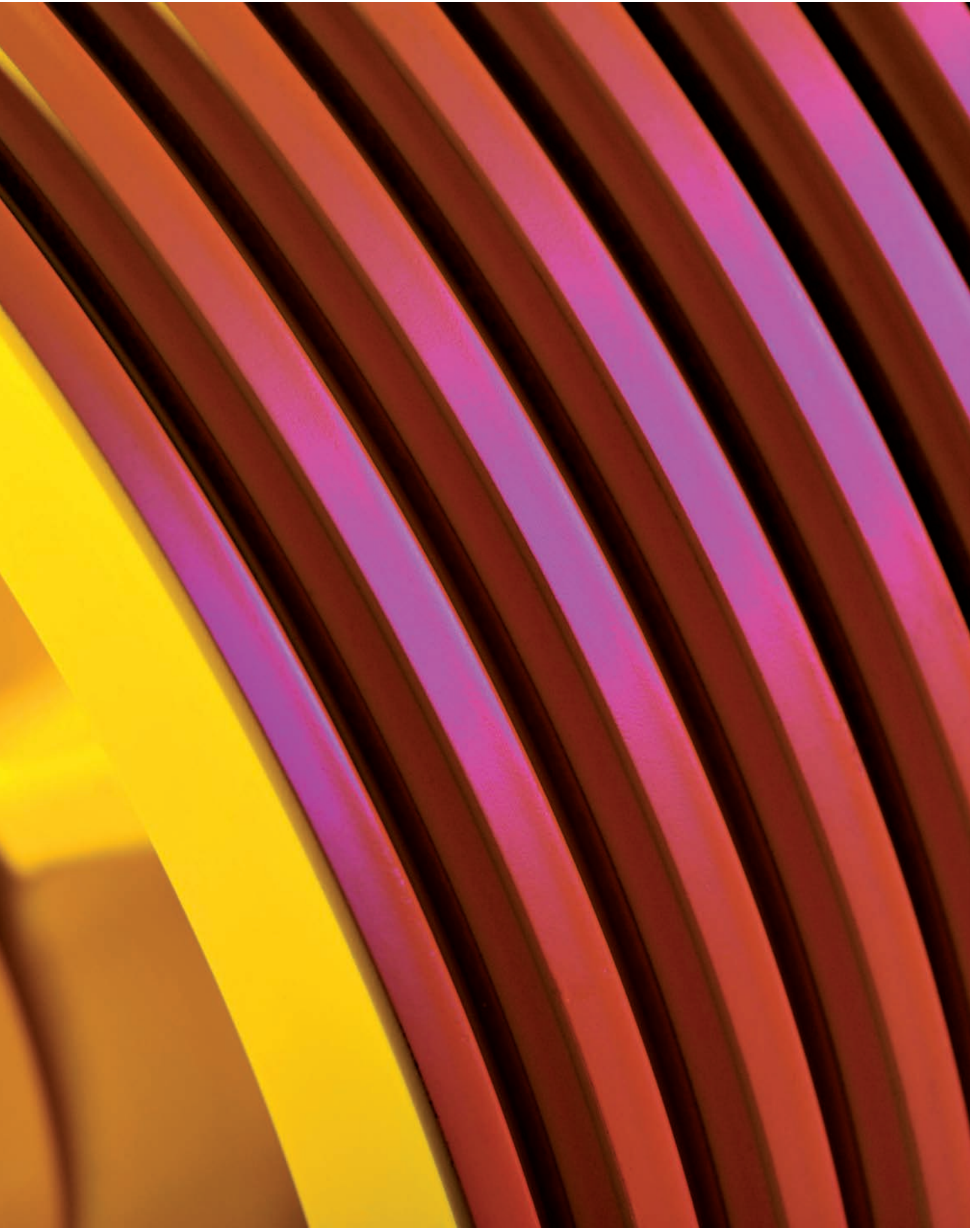

Information

ZAtop

ZAsyn

ZAdisc

VFD

System components motors

Control technology

System components control technology

Appendix

The Royal League of elevator machines



Maximum benefit for manufacturers and user

Meeting the requirements of elevator builders, owners and passengers is the decisive success factor for elevator manufacturers. As a partner to leading manufacturers, ZIEHL-ABEGG constantly strives to make the maximum contribution to satisfying these needs. This goal is reflected in many ways. For example in the cost saving and environmentally friendliness of the elevators thanks to the high efficiency of the ZIEHL-ABEGG motor technology with the precisely adapted control technology. Or in the certainty of getting the ideal drive for every architectural and constructional requirement: Low-noise, with and without gear, as a synchronous or asynchronous motor, with powerful, compact drives right down to small motors for minimal shaft volumes. ZIEHL-ABEGG also demonstrates their solution competence in highly intelligent frequency inverters and evacuation units and in user-friendly diagnostic software. But the root of all considerations is still the passenger and the fulfilment of his needs: Maximum reliability and greatest drive comfort. ZIEHL-ABEGG makes the best possible contribution to this.



Information

ZAtop

ZAsyn

ZAdisc

VFD

System components motors

Control technology

System components control technology

Appendix

The Royal League of modernisation



Obtained values - securing the future

ZIEHL-ABEGG offers maximum customer benefits quickly and simply: They turn old elevators into efficient, energy saving, comfortable and low-noise systems. Often just a few but all the more intelligent retrofits suffice. ZIEHL-ABEGG has a wide range of high-tech components ready for this. The customer gets innovating solution suggestions. The competence of ZIEHL-ABEGG and the use of the high quality and high efficiency products result in a reasonable and profitable investment. Drives with the highest standards and in different sizes as well as precisely adapted control engineering and suitable machine frames are a central part of the product portfolio.

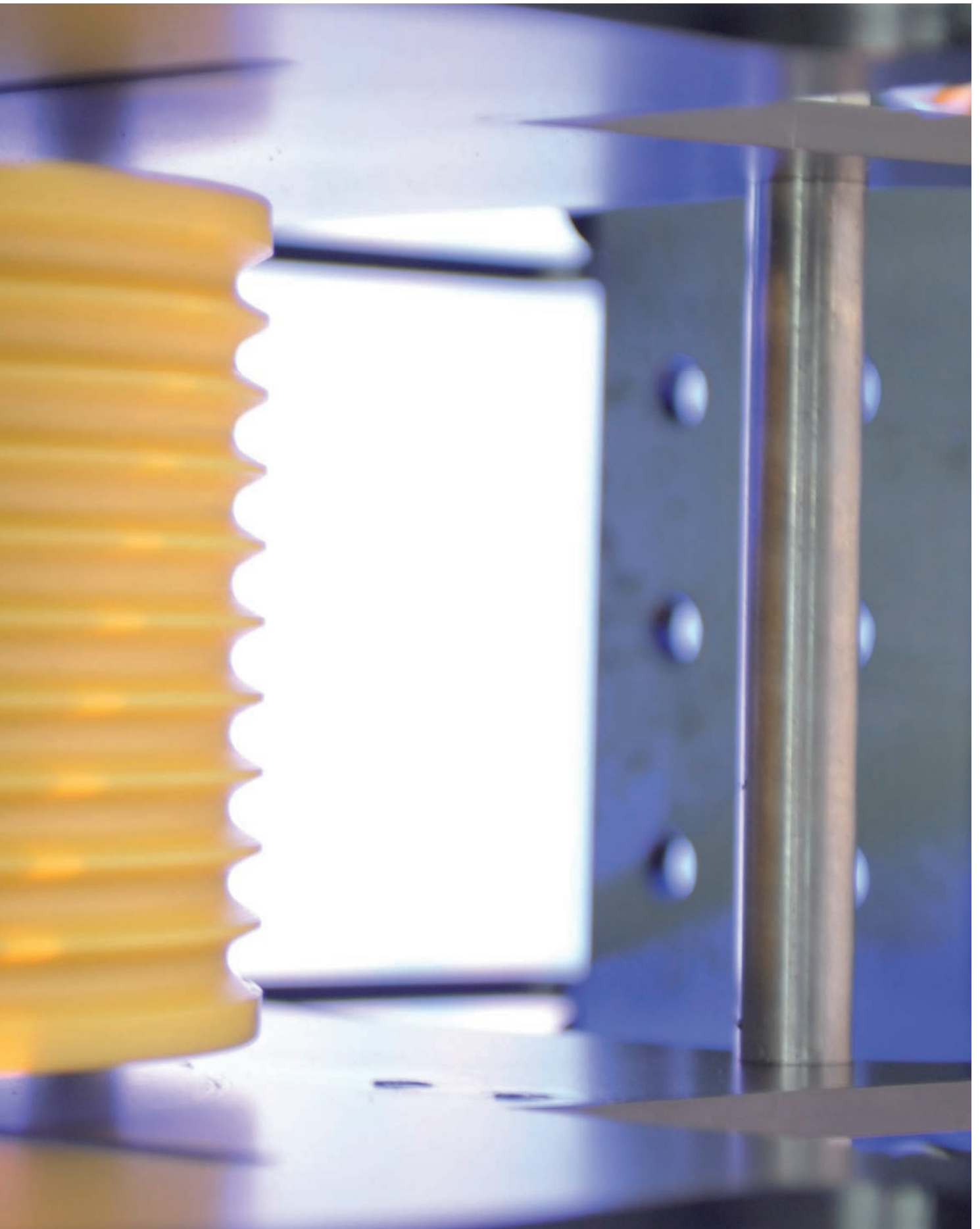

Information

ZAtop

ZAsyn

ZAdisc

VFD

System components motors

Control technology

System components control technology

Appendix



Gearless elevator machine ZAtop

Product overview

Information	Page 14
ZAtop SM132/A	Page 16
ZAtop SM132/B	Page 18
ZAtop SM160	Page 20
ZAtop SM180	Page 22
ZAtop SM190	Page 24
ZAtop SM200	Page 26
ZAtop SM210	Page 28
ZAtop SM225	Page 30
ZAtop SM250B / SM250D	Page 32
ZAtop SM250C	Page 34

Information

ZAtop

ZAsyn

ZAdisc

VFD

System components
motorsControl
technologySystem components
control
technology

Appendix

ZAtop Gearless elevator machine

General information

The top solution for elevators with and without a machine room

Properties

- Gearless synchronous motor actuated by NdFeB permanent magnets
- Internal rotor motor
- According to the provisions of the Lift Directive 2014/33/EU
- Various frame sizes for optimum shaft and shaft head dimensions
- High efficiency
- Noise emissions < 50 dB(A)
- Insulation class F (155°C) with temperature monitoring via PTC thermistor
- Travel speeds of up to 4.0 m/s
- Rope diameter of 4.0 to 16.0 mm
- Traction sheaves:
 - Diameter of 120 mm to 640 mm
 - Various groove geometries
- Motor brake:
 - Safety component according to the Lift Directive 2014/33/EU
 - Separately actuated brake circuits
 - Deployable as an element of the ascending car overspeed protection means
 - Deployable as part of the protection against unintended car movement
 - Mechanical hand release (optional)
- Can be equipped with conventional encoder systems (e.g. EnDat, SSI, SinCos)
- Optimum package solution with ZAdyn frequency inverter from ZIEHL-ABEGG

A glimpse inside

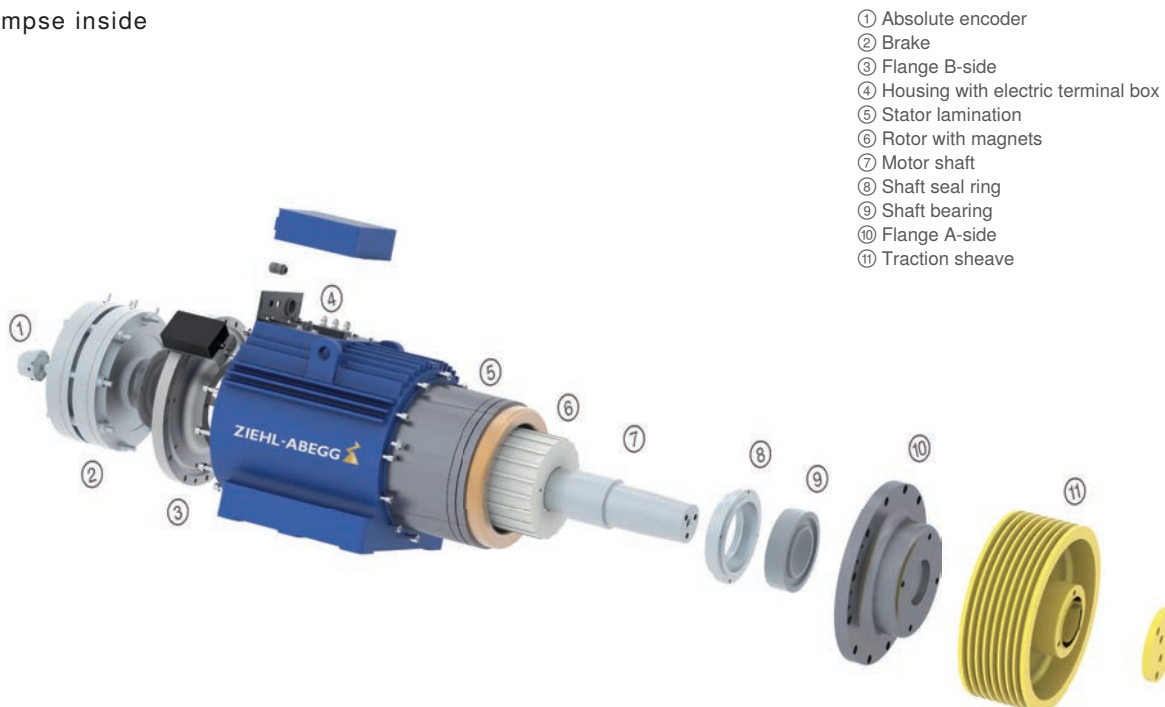

Product portfolio ZAtop

ZIEHL-ABEGG offers you the most comprehensive range of gearless elevator machines with the greatest flexibility and variability.

Suspension	Rated load max. kg	Traction sheave diameter mm	Axle load kg	ZAtop	Page
2:1	1050	120...160	2400	SM132/A 	Page 16
	1050	120...200	2400	SM132/B 	Page 18
	1125	160...240	1900...2500	SM160 	Page 20
	1050	200...240	1500...2500	SM180 	Page 22
	1200	200...240	1850...2400	SM190 	Page 24
	1600	160...500	1850...3600	SM200 	Page 26
	2500	240...520	4500	SM210 	Page 28
	2000	240...640	5300	SM225 	Page 30
	3000	320...640	6000...8000	SM250.45 SM250.60 SM250.80 	Page 32
	3500	450...520	13000	SM250.100 	Page 34

Information

ZAtop

ZAsyn

ZAdisc

VFD

System components motors

Control technology

System components control technology

Appendix

ZAtop Gearless elevator machine

SM132/A



Synchronous motor actuated by permanent magnets and according to the provisions of the Lift Directive 2014/33/EU

Drive

- NdFeB magnets
- Structural width ≤ 205 mm for the narrowest shaft dimensions
- Noise emissions: < 50 dB(A)
- Insulation class F with temperature monitoring

Brake system

- Safety component according to the Lift Directive 2014/33/EU
- Separately activated brake circuits
- Deployable as an element of the ascending car overspeed protection means
- Deployable as part of the protection against unintended car movement

Deflection pulleys	Page 66
ZAlift	Page 70

Technical data

SM132/A

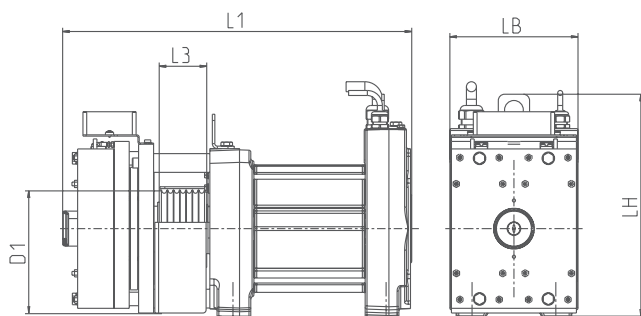

Motor type	Nominal torque Nm	Max. axle load kg	Nominal speed min ⁻¹	Rated output power kW	L1 mm	LH mm	LB mm	D1 mm	L3 mm	Weight kg
SM132.21	120	2400	162...510	2.0...6.4	468	355	205	120	56	115
								160		120
SM132.35	200	2400	162...510	3.4...10.7	559	355	205	120	76	140
								160		145



Scope of delivery and options

SM132/A	Standard	Options
Motor	Gearless elevator machine	-
Traction sheave	See D1	-
Brake	Certified brake system	Mechanical hand release
Brake monitoring	Microswitch	Inductive proximity switches
Motor cable	5 m	10 m, 15 m, 20 m, 25 m, halogen free
Absolute encoder type Heidenhain	ECN 1313 EnDat	ECN 1313 SSI, ERN 1387, ERN 1326
Rope guard	2 pieces	3. rope guard
Temperature monitoring	PTC thermistor	KTY thermistor
Cooling	Surface cooling	-

Resulting rope force

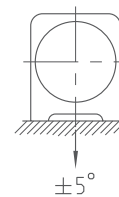

Example configurations

Other configurations, also outside of the examples listed below, are possible. Our calculation software ZAlift is available to you for fast and convenient calculation of your elevator machine.

Suspension	Max. payload kg	Speed m/s	Motor type	Traction sheave mm	Rope Number x Ø mm	Motor power kW	Rated current A
1:1	300	1.0	SM132.21	120	5 x 6.5	2.0	6.5
	450	1.0	SM132.35	160	6 x 6.5	2.8	11.8
	480	1.0	SM132.35	120	6 x 6.5	3.0	9.4
	550	1.0	SM132.35	120	7 x 6.5	3.4	10.8
	550	1.6	SM132.35	120	7 x 6.5	5.5	19.0
2:1	300	1.0	SM132.21	160	4 x 6.5	2.1	6.2
	450	1.0	SM132.21	160	4 x 6.5	3.0	8.9
	630	1.0	SM132.21	120	5 x 6.5	4.4	12.5
	630	1.6	SM132.21	120	4 x 6.5	6.5	17.1
	800	1.0	SM132.35	160	6 x 6.5	6.5	19.2
	1050	1.0	SM132.35	120	7 x 6.5	6.7	18.7

Information

ZAtop

ZAsyn

ZAdisc

VFD

System components motors

Control technology

System components control technology

Appendix



ZAtop Gearless elevator machine

SM132/B



Synchronous motor actuated by permanent magnets and according to the provisions of the Lift Directive 2014/33/EU

Drive

- NdFeB magnets
- Structural width ≤ 205 mm for the narrowest shaft dimensions
- Noise emissions: < 50 dB(A)
- Insulation class F with temperature monitoring

Brake system

- Safety component according to the Lift Directive 2014/33/EU
- Separately activated brake circuits
- Deployable as an element of the ascending car overspeed protection means
- Deployable as part of the protection against unintended car movement

Deflection pulleys	Page 66
ZAlift	Page 70
Machine frames	Page 56

Technical data

SM132/B

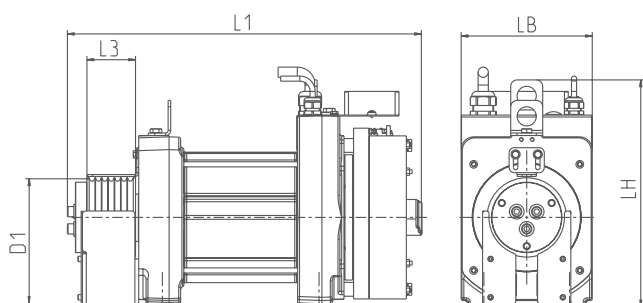

Motor type	Nominal torque Nm	Max. axle load kg	Nominal speed min ⁻¹	Rated output power kW	L1 mm	LH mm	LB mm	D1 mm	L3 mm	Weight kg
SM132.21	120	2400	162...510	2.0...6.4	465	355	205	120	56	105
							205	160		110
							220	200		110
SM132.35	200	2400	162...510	3.4...10.7	555	355	205	120	76	165
							205	160		170
							220	200		170

Scope of delivery and options

SM132/B	Standard	Options
Motor	Gearless elevator machine	-
Traction sheave	See D1	-
Brake	Certified brake system	Mechanical hand release
Brake monitoring	Microswitch	Inductive proximity switches
Motor cable	5 m	10 m, 15 m, 20 m, 25 m, halogen free
Absolute encoder type Heidenhain	ECN 1313 EnDat	ECN 1313 SSI, ERN 1387, ERN 1326
Rope guard	2 pieces	3. rope guard
Temperature monitoring	PTC thermistor	KTY thermistor
Cooling	Surface cooling	-

Resulting rope force

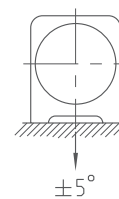

Example configurations

Other configurations, also outside of the examples listed below, are possible. Our calculation software ZAlift is available to you for fast and convenient calculation of your elevator machine.

Suspension	Max. payload kg	Speed m/s	Motor type	Traction sheave mm	Rope Number x Ø mm	Motor power kW	Rated current A
1:1	300	1.0	SM132.21	120	5 x 6.5	2.0	6.5
	300	1.0	SM132.35	200	6 x 6.5	2.2	12.3
	450	1.0	SM132.35	160	6 x 6.5	2.8	11.8
	480	1.0	SM132.35	120	6 x 6.5	3.0	9.4
	550	1.0	SM132.35	120	7 x 6.5	3.4	10.8
2:1	550	1.6	SM132.35	120	7 x 6.5	5.5	19.0
	300	1.0	SM132.21	160	4 x 6.5	2.1	6.2
	450	1.0	SM132.21	160	4 x 6.5	3.0	8.9
	525	1.0	SM132.35	200	5 x 6.5	3.8	14.3
	525	2.0	SM132.35	200	6 x 6.5	7.8	20.6
	630	1.0	SM132.21	120	5 x 6.5	4.4	12.5
	630	1.6	SM132.21	120	4 x 6.5	6.5	17.1
800	1.0	SM132.35	160	6 x 6.5	6.5	19.2	
1050	1.0	SM132.35	120	7 x 6.5	6.7	18.7	

Information

ZAtop

ZAsyn

ZAdisc

VFD

System components motors

Control technology

System components control technology

Appendix



ZAtop Gearless elevator machine

SM160



Synchronous motor actuated by permanent magnets and according to the provisions of the Lift Directive 2014/33/EU

Drive

- NdFeB magnets
- Structural width ≤ 250 mm for the narrowest shaft dimensions
- Noise emissions: < 50 dB(A)
- Insulation class F with temperature monitoring

Brake system

- Safety component according to the Lift Directive 2014/33/EU
- Separately activated brake circuits
- Deployable as an element of the ascending car overspeed protection means
- Deployable as part of the protection against unintended car movement

Machine frames	Page 56
Deflection pulleys	Page 66
Adapter plates	Page 65
ZAlift	Page 70

Technical data

SM160

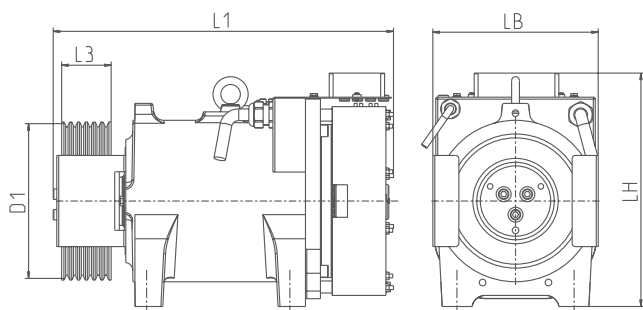

Motor type	Nominal torque Nm	Max. axle load kg	Nominal speed min ⁻¹	Rated output power kW	L1 mm	LH mm	LB mm	D1 mm	L3 mm	Weight kg
SM160.30B/S	195	1900	192...384	3.9...7.8	532	359	248	120	101	140
					531		248	160	101	146
					523		248	200	76	149
					523		248	210	76	150
					523		254	240	76	155
SM160.40B/S	260	2500	192...384	5.2...10.5	617	359	248	120	140	165
					615		248	160	140	172
					596		248	210	106	178
					596		254	240	88	181



Scope of delivery and options

SM160	Standard	Options
Motor	Gearless elevator machine	-
Traction sheave	See D1	-
Brake	Certified brake system	Mechanical hand release
Brake monitoring	Microswitch	Inductive proximity switches
Motor cable	5 m	10 m, 15 m, 20 m, 25 m, halogen free
Absolute encoder type Heidenhain	ECN 1313 EnDat	ECN 1313 SSI, ERN 1387, ERN 1326
Rope guard	2 pieces	-
Temperature monitoring	PTC thermistor	KTY thermistor
Cooling	Surface cooling	Forced ventilation

Resulting rope force

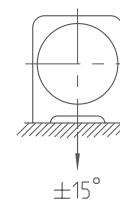

Example configurations

Other configurations, also outside of the examples listed below, are possible. Our calculation software ZAlift is available to you for fast and convenient calculation of your elevator machine.

Suspension	Max. payload kg	Speed m/s	Motor type	Traction sheave mm	Rope Number x Ø mm	Motor power kW	Rated current A
1:1	300	1.0	SM160.30B/S	200	7 x 6.5	3.3	11.3
	450	1.0	SM160.40B/S	160	5 x 6.5	3.5	11.5
	480	1.0	SM160.40B/S	160	5 x 6.5	3.7	12.2
	550	1.6	SM160.40B/S	160	6 x 6.5	5.4	14.0
2:1	300	1.0	SM160.30B/S	200	4 x 6.5	4.4	10.5
	450	1.0	SM160.30B/S	200	5 x 6.5	5.1	12.3
	630	1.0	SM160.40B/S	210	7 x 6.5	7.2	18.1
	675	1.0	SM160.40B/S	240	7 x 6.5	5.9	14.8
	800	1.0	SM160.30B/S	160	6 x 6.5	6.5	16.0
	1125	1.0	SM160.40B/S	160	7 x 6.5	7.1	18.0

Information

ZAtop

ZAsyn

ZAdisc

VFD

System components motors

Control technology

System components control technology

Appendix



ZAtop Gearless elevator machine

SM180



Synchronous motor actuated by permanent magnets and according to the provisions of the Lift Directive 2014/33/EU

Drive

- NdFeB magnets
- Structural width ≤ 256 mm for the narrowest shaft dimensions
- Noise emissions: < 50 dB(A)
- Insulation class F with temperature monitoring

Brake system

- Safety component according to the Lift Directive 2014/33/EU
- Separately activated brake circuits
- Deployable as an element of the ascending car overspeed protection means
- Deployable as part of the protection against unintended car movement

Deflection pulleys	Page 66
Forced ventilation	Page 67
ZAlift	Page 70
Motor cables	Page 108

Technical data

SM180

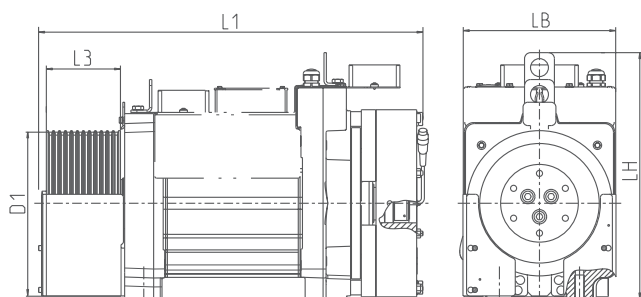

Motor type	Nominal torque Nm	Max. axle load kg	Nominal speed min ⁻¹	Rated output power kW	L1 mm	LH mm	LB mm	D1 mm	L3 mm	Weight kg
SM180.24/B	215	2500	162...192	3.6...4.3	513	412	255	200	79	165
							256	240		170
SM180.35/B	295	2500	162...306	5.0...9.5	568	412	255	200	88	190
							256	240		195
SM180.45/B	385	2500	162...306	7.5...12.3	643	412	255	200	124	235
							256	240		240



Scope of delivery and options

SM180	Standard	Options
Motor	Gearless elevator machine	-
Traction sheave	See D1	-
Brake	Certified brake system	Mechanical hand release
Brake monitoring	Microswitch	Inductive proximity switches
Motor cable	-	5 m, 10 m, 15 m, 20 m, 25 m, halogen free
Absolute encoder type Heidenhain	BiSS-C	ECN 1313 EnDat, ECN 1313 SSI, ERN 1387, ERN 1326
Rope guard	2 pieces	3. rope guard
Temperature monitoring	PTC thermistor	KTY thermistor
Cooling	Surface cooling	Forced ventilation

Resulting rope force

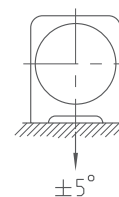

Example configurations

Other configurations, also outside of the examples listed below, are possible. Our calculation software ZAlift is available to you for fast and convenient calculation of your elevator machine.

Suspension	Max. payload kg	Speed m/s	Motor type	Traction sheave mm	Rope Number x Ø mm	Motor power kW	Rated current A
2:1	480	1.0	SM180.24/B	200	5 x 6.5	4.3	11.0
	480	1.0	SM180.24/B	240	6 x 6.5	3.6	11.0
	675	1.0	SM180.35/B	200	7 x 6.5	5.9	16.0
	675	1.0	SM180.35/B	240	6 x 6.5	5.0	14.0
	675	1.6	SM180.35/B	200	7 x 6.5	9.5	22.0
	675	1.6	SM180.35/B	240	6 x 6.5	8.0	19.5
	1050	1.0	SM180.45/B	200	10 x 6.5	7.7	20.0
	1050	1.0	SM180.45/B	240	8 x 6.5	7.5	21.0
	1050	1.6	SM180.45/B	200	10 x 6.5	12.3	31.0
	1050	1.6	SM180.45/B	240	8 x 6.5	12.0	31.0

Information

ZAtop

ZAsyn

ZAdisc

VFD

System components motors

Control technology

System components control technology

Appendix



ZAtop Gearless elevator machine

SM190



Synchronous motor actuated by permanent magnets and according to the provisions of the Lift Directive 2014/33/EU

Drive

- NdFeB magnets
- Structural width ≤ 320 mm for the narrowest shaft dimensions
- Noise emissions: < 50 dB(A)
- Insulation class F with temperature monitoring

Brake system

- Safety component according to the Lift Directive 2014/33/EU
- Separately activated brake circuits
- Deployable as an element of the ascending car overspeed protection means
- Deployable as part of the protection against unintended car movement

Machine frames	Page 56
Deflection pulleys	Page 66
Adapter plates	Page 65
ZAlift	Page 70

Technical data

SM190

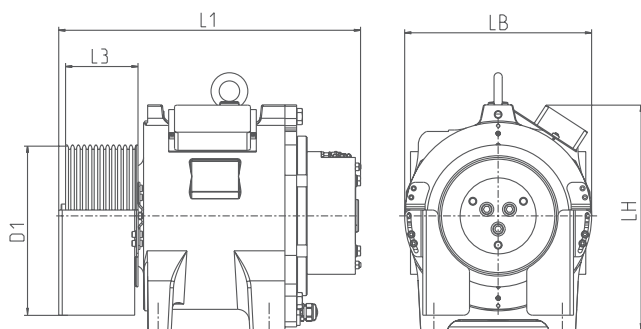

Motor type	Nominal torque	Max. axle load	Nominal speed	Rated output power	L1	LH	LB	D1	L3	Weight
	Nm	kg	min ⁻¹	kW	mm	mm	mm	mm	mm	kg
SM190.15	250	1850	168...192	4.4...5.0	483	385	320	200	76	160
								240	88	166
SM190.23	380	2400	168...192	6.7...7.6	515	385	320	200	106	195
								240	124	204



Scope of delivery and options

SM190	Standard	Options
Motor	Gearless elevator machine	-
Traction sheave	See D1	-
Brake	Certified brake system	-
Brake monitoring	Microswitch	-
Motor cable	10 m	-
Absolute encoder type Heidenhain	ECN 1313 EnDat	-
Rope guard	2 pieces	3. rope guard
Temperature monitoring	PTC thermistor	KTY thermistor
Cooling	Surface cooling	Forced ventilation

Resulting rope force

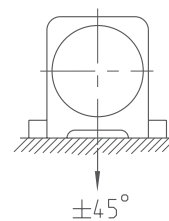

wit lateral form lock support

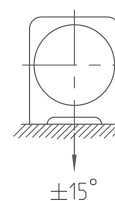

Example configurations

Other configurations, also outside of the examples listed below, are possible. Our calculation software ZAlift is available to you for fast and convenient calculation of your elevator machine.

Suspension	Max. payload kg	Speed m/s	Motor type	Traction sheave mm	Rope Number x Ø mm	Motor power kW	Rated current A
1:1	300	1.6	SM190.15	200	6 x 6.5	3.3	10.6
	450	1.6	SM190.23	240	7 x 6.5	4.8	17.5
2:1	300	1.0	SM190.15	200	4 x 6.5	2.2	6.3
	450	1.0	SM190.15	200	5 x 6.5	3.2	9.2
	630	1.0	SM190.15	240	6 x 6.5	4.4	13.5
	675	1.0	SM190.15	200	7 x 6.5	4.8	13.6
	1050	1.0	SM190.23	200	9 x 6.5	7.2	19.9
	1200	1.0	SM190.23	200	7 x 6.5	7.6	21.1

Information

ZAtop

ZAsyn

ZAdisc

VFD

System components motors

Control technology

System components control technology

Appendix



ZAtop gearless elevator machine

SM200



SM200.15C/20C/30C



SM200.40C

Synchronous motor actuated by permanent magnets and according to the provisions of the Lift Directive 2014/33/EU

Drive

- NdFeB magnets
- Structural width ≤ 320 mm for the narrowest shaft dimensions
- Noise emissions: < 50 dB(A)
- Insulation class F with temperature monitoring

Brake system

- Safety component according to the Lift Directive 2014/33/EU
- Separately activated brake circuits
- Deployable as an element of the ascending car overspeed protection means
- Deployable as part of the protection against unintended car movement

Technical data

SM200

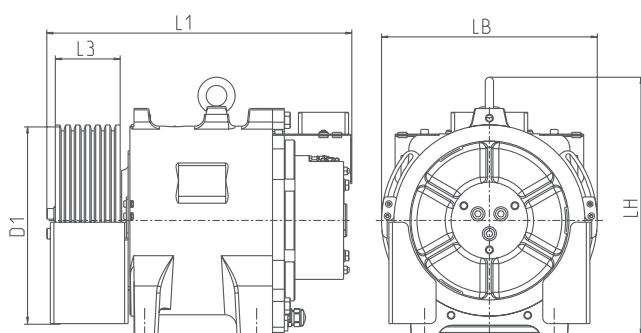

Motor cables	Page 108
Machine frames	Page 56
Deflection pulleys	Page 66
Adapter plates	Page 65
Forced ventilation	Page 67
ZAlift	Page 70

Motor type	Nominal torque Nm	Max. axle load kg	Nominal speed min ⁻¹	Rated output power kW	L1 mm	LH mm	LB mm	D1 mm	L3 mm	Weight kg	
SM200.15C	250	1850	96...300	2.5...7.9	487	385	308	160	76	167	
							308	200	76	171	
							308	210	76	175	
							308	240	88	180	
							340	320	74	185	
SM200.20C	330	2800	96...300	3.3...10.4	517	385	308	160	106	187	
							308	200	106	193	
							308	210	106	195	
							308	240	124	205	
							340	320	110	210	
							420	400	92	230	
							485	450	92	235	
SM200.30C	475	2800	96...300	4.8...14.1	564		320	200	106	225	
							320	210	106	235	
							320	240	124	240	
							360	320	110	260	
							422	400	92	265	
							474	450	92	265	
SM200.40D	600	3300	96...300	6.0...18.8	668	451	322	160	143	269	
							637	200	106	271	
							637	240	124	284	
							685	322	240	173	292
							640	360	320	122	296
							637	422	400	95	299
							637	520	500	90	318
							637	520	500	90	318
SM200.45D	710	3600	96...300	7.1...20.4	668	451	322	160	143	280	
							637	200	106	282	
							637	240	124	295	
							685	322	240	173	303
							640	360	320	122	307
							637	422	400	95	310
							637	520	500	90	329



Scope of delivery and options

SM200	Standard	Options
Motor	Gearless elevator machine	-
Traction sheave	See D1	-
Brake	Certified brake system	Mechanical hand release
Brake monitoring	Microswitch	Inductive proximity switches (SM200.15C to SM200.30C)
Motor cable	5 m (SM200.15C to SM200.30C)	5 m, 10 m, 15 m, 20 m, 25 m, halogen free
Absolute encoder type Heidenhain	ECN 1313 EnDat	ECN 1313 SSI, ERN 1387, ERN 1326
Rope guard	2 pieces	3. rope guard
Temperature monitoring	PTC thermistor	KTY thermistor
Cooling	Surface cooling	Forced ventilation

Resulting rope force

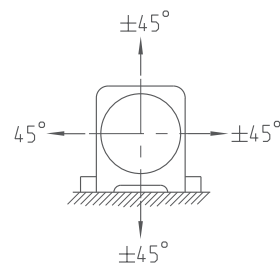

wit lateral form lock support

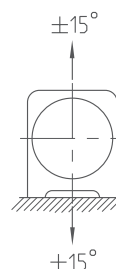

without lateral form lock support

Example configurations

Other configurations, also outside of the examples listed below, are possible. Our calculation software ZAlift is available to you for fast and convenient calculation of your elevator machine.

Suspension	Max. payload kg	Speed m/s	Motor type	Traction sheave mm	Rope Number x Ø mm	Motor power kW	Rated current A
1:1	300	1.0	SM200.15C	240	6 x 6.5	2.0	8.8
	300	1.0	SM200.30C	400	3 x 10	3.4	12.8
	450	1.0	SM200.30C	240	8 x 6.5	3.1	11.3
	630	1.0	SM200.40D	320	5 x 8	4.0	18.8
	675	1.6	SM200.20C	160	8 x 6.5	6.7	19.2
	675	1.6	SM200.45D	320	5 x 8	6.9	20.3
	800	1.6	SM200.40D	160	9 x 6.5	7.9	21.0
2:1	450	1.25	SM200.15C	320	4 x 8	4.2	14.3
	630	1.6	SM200.20C	320	4 x 8	7.2	20.8
	675	1.6	SM200.15C	200 / 210	7 x 6.5	7.8	22.1
	800	1.0	SM200.20C	200	7 x 6.5	5.7	16.3
	800	1.6	SM200.30C	320	4 x 8	8.9	22.8
	1000	1.0	SM200.40D	320	6 x 8	7.1	19.9
	1000	2.5	SM200.40D	320	6 x 8	17.8	41.7
	1050	1.6	SM200.45D	400	6 x 8	11.5	31.9
	1200	1.0	SM200.20C	160	6 x 6.5	7.7	23.2
	1200	1.6	SM200.30C	200	6 x 6.5	12.2	29.7
	1350	1.6	SM200.45D	320	6 x 8	14.7	39.9
1600	1.6	SM200.45D	240	12 x 6.5	18.1	45.8	

ZAtop Gearless elevator machine

SM210



Synchronous motor actuated by permanent magnets and according to the provisions of the Lift Directive 2014/33/EU

Drive

- NdFeB magnets
- Structural width ≤ 340 mm for the narrowest shaft dimensions
- Noise emissions: < 50 dB(A)
- Insulation class F with temperature monitoring

Brake system

- Safety component according to the Lift Directive 2014/33/EU
- Separately activated brake circuits
- Deployable as an element of the ascending car overspeed protection means
- Deployable as part of the protection against unintended car movement

Deflection pulleys	Page 66
Forced ventilation	Page 67
ZAlift	Page 70
Motor cables	Page 108

Technical data

SM210

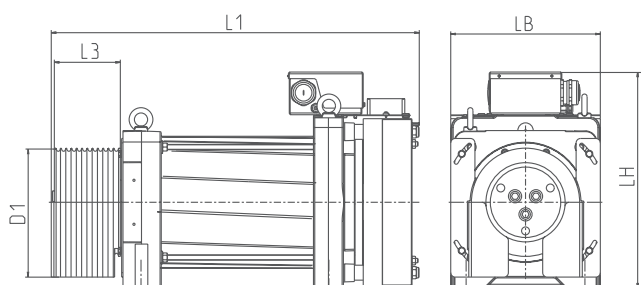

Motor type	Nominal torque Nm	Max. axle load kg	Nominal speed min ⁻¹	Rated output power kW	L1 mm	LH mm	LB mm	D1 mm	L3 mm	Weight kg
SM210.60B	850	4400	60...258	5.3...21.6	806	491	340	240	150	460
							340	320		470
							430*	320		470
							484	400		490
							543	520		515
SM210.70B	1000	4400	60...258	6.3...25.7	856	491	340	240	150	485
							340	320		495
							430*	320		495
							484	400		515
							543	520		540

* at wrap angle $> 180^\circ$



Scope of delivery and options

SM210	Standard	Options
Motor	Gearless elevator machine	-
Traction sheave	See D1	-
Brake	Certified brake system	Mechanical hand release
Brake monitoring	Microswitch	Inductive proximity switches
Motor cable	-	5 m, 10 m, 15 m, 20 m, 25 m, halogen free
Absolute encoder type Heidenhain	ECN 1313 EnDat	ECN 1313 SSI, ERN 1387, ERN 1326
Rope guard	2 pieces	3. rope guard
Temperature monitoring	PTC thermistor	KTY thermistor
Cooling	Surface cooling	Forced ventilation

Resulting rope force

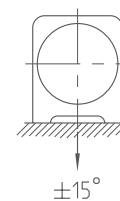

Example configurations

Other configurations, also outside of the examples listed below, are possible. Our calculation software ZAlift is available to you for fast and convenient calculation of your elevator machine.

Suspension	Max. payload kg	Speed m/s	Motor type	Traction sheave mm	Rope Number x Ø mm	Motor power kW	Rated current A
1:1	675	1.0	SM210.60	400	4 x 10	4.6	17.7
	800	1.0	SM210.60	320	8 x 8	5.2	16.6
	1000	1.6	SM210.70	320	10 x 8	10.1	30.7
	1000	2.5	SM210.60	520	3 x 13	18.1	48.5
	1250	1.6	SM210.60	400	5 x 10	13.9	35.6
	1600	1.0	SM210.60	320	10 x 8	11.1	29.8
	1600	1.6	SM210.70	400	7 x 10	16.3	48.0
	2000	1.0	SM210.70	320	10 x 8	13.5	35.4
4:1	3000	1.0	SM210.70	400	6 x 10	20.1	55.9

Information

ZAtop

ZAsyn

ZAdisc

VFD

System components motors

Control technology

System components control technology

Appendix



ZAtop Gearless elevator machine

SM225



Synchronous motor actuated by permanent magnets and according to the provisions of the Lift Directive 2014/33/EU

Drive

- NdFeB magnets
- Structural width ≤ 410 mm
- Noise emissions: < 50 dB(A)
- Insulation class F with temperature monitoring

Brake system

- Safety component according to the Lift Directive 2014/33/EU
- Separately activated brake circuits
- Deployable as an element of the ascending car overspeed protection means
- Deployable as part of the protection against unintended car movement

Motor cables	Page 108
Machine frames	Page 56
Deflection pulleys	Page 66
Adapter plates	Page 65
Forced ventilation	Page 67
ZAlift	Page 70

Technical data

SM225

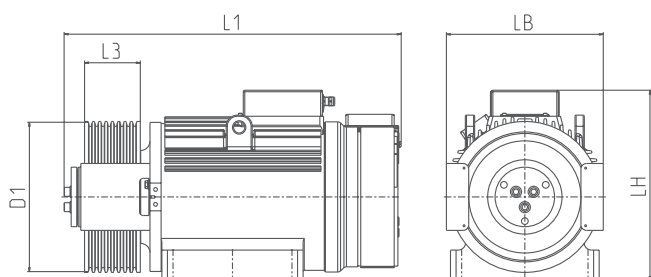

Motor type	Nominal torque Nm	Max. axle load kg	Nominal speed min ⁻¹	Rated output power kW	L1 mm	LH mm	LB mm	D1 mm	L3 mm	Weight kg
SM225.60B	1120	5300	60...336	7.0...31.5	907	512	410	280	130	590
							410	320	182	605
							425	400	150	615
							520	500	150	640
							543	520	150	643
							620	600	150	665
							660	640	150	720

Scope of delivery and options

SM225	Standard	Options
Motor	Gearless elevator machine	-
Traction sheave	See D1	-
Brake	Certified brake system	Mechanical hand release
Brake monitoring	Microswitch	Inductive proximity switches
Motor cable	-	5 m, 10 m, 15 m, 20 m, 25 m, halogen free
Absolute encoder type Heidenhain	ECN 1313 EnDat	ECN 1313 SSI, ERN 1387, ERN 1326
Rope guard	2 pieces	3. rope guard
Temperature monitoring	PTC thermistor	KTY thermistor
Cooling	Surface cooling	Forced ventilation

Resulting rope force

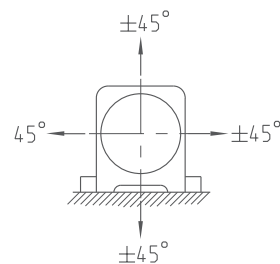

wit lateral form lock support

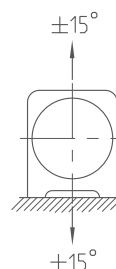

without lateral form lock support

Example configurations

Other configurations, also outside of the examples listed below, are possible. Our calculation software ZAlift is available to you for fast and convenient calculation of your elevator machine.

Suspension	Max. payload kg	Speed m/s	Motor type	Traction sheave mm	Rope Number x Ø mm	Motor power kW	Rated current A
1:1	1000	1.6	SM225.60B	320	10 x 8	10.7	28.8
	1000	2.0	SM225.60B	320	10 x 8	13.4	35.2
2:1	800	1.6	SM225.60B	600	4 x 10	10.5	30.7
	1000	1.6	SM225.60B	640	2 x 14	9.8	30.8
	1000	2.5	SM225.60B	320	6 x 8	19.5	45.7
	1250	2.5	SM225.60B	400	5 x 10	25.3	63.9
	1600	1.0	SM225.60B	320	10 x 8	12.6	37.7
	1600	2.0	SM225.60B	320	10 x 8	22.9	57.7
4:1	2000	1.6	SM225.60B	320	10 x 8	22.1	59.2
	3000	1.0	SM225.60B	400	6 x 10	21.5	57.4

Travel distance: 25 m at 1 m/s, 35-40 m at 1.6 m/s

ZAtop Gearless elevator machine

SM250.45 / SM250.60 / SM250.80



SM250.60B



SM250.80D

Synchronous motor actuated by permanent magnets and according to the provisions of the Lift Directive 2014/33/EU

Drive

- NdFeB magnets
- For fast elevators of up to 4 m/s
- Noise emissions: < 50 dB(A)
- Insulation class F with temperature monitoring

Brake system

- Safety component according to the Lift Directive 2014/33/EU
- Separately activated brake circuits
- Deployable as an element of the ascending car overspeed protection means
- Deployable as part of the protection against unintended car movement

Motor cables	Page 108
Machine frames	Page 56
Deflection pulleys	Page 66
Adapter plates	Page 65
Forced ventilation	Page 67
ZAlift	Page 70

Technical data

SM250

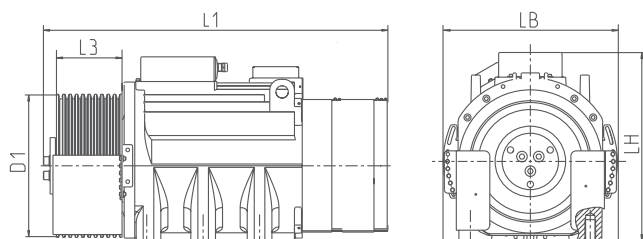

Motor type	Nominal torque Nm	Max. axle load kg	Nominal speed min ⁻¹	Rated output power kW	L1 mm	LH mm	LB mm	D1 mm	L3 mm	Weight kg							
SM250.45B	1120	6000	60...300	4.5...23.6	915	535	410	320	182	635							
							445	400	186	650							
							460	400*	186	650							
							520	500	150	670							
							543	520	150	680							
							620	600	150	695							
SM250.60B	1600	6000	60...336	10.0...42.0	977	535	410	320	182	670							
							425	400	150	675							
							445	400*	186	685							
							460	400*	186	685							
							520	500	150	705							
							543	520	150	715							
SM250.80D	2000	8000	60...300	12.6...62.8	1147	645	474	440	200	1010							
							528	440*		1021							
							546	520		1041							
							666	640		1128							
							SM250.80D-FB	2500	8000	54...276	14.1...72.3	1147	645	474	440	200	1010
														528	440*		1021
546	520		1041														
666	640		1128														

* at wrap angle > 180 °



Scope of delivery and options

SM250	Standard	Options
Motor	Gearless elevator machine	-
Traction sheave	See D1	-
Brake	Certified brake system	Mechanical hand release
Brake monitoring	Microswitch	Inductive proximity switches
Motor cable	-	5 m, 10 m, 15 m, 20 m, 25 m, halogen free
Absolute encoder type Heidenhain	ECN 1313 EnDat	ECN 1313 SSI, ERN 1387, ERN 1326
Rope guard	2 pieces	3. rope guard
Temperature monitoring	PTC thermistor	KTY thermistor
Cooling	Surface cooling	Forced ventilation

Resulting rope force

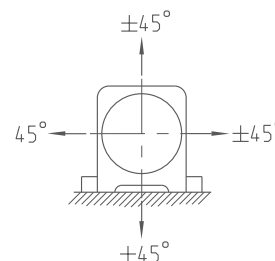

wit lateral form lock support

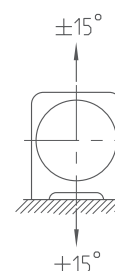

without lateral form lock support

Example configurations

Other configurations, also outside of the examples listed below, are possible. Our calculation software ZAlift is available to you for fast and convenient calculation of your elevator machine.

Suspension	Max. payload kg	Speed m/s	Motor type	Traction sheave mm	Rope Number x Ø mm	Motor power kW	Rated current A
1:1	1000	1.0	SM250.45B	320	10 x 8	10.7	28.8
	1000	2.0	SM250.45B	320	10 x 8	13.4	35.2
	1000	1.6	SM250.60B	400	8 x 10	11.1	37.3
	1250	1.6	SM250.80D	520	7 x 11	13.5	58.9
	1250	2.5	SM250.80D	520	7 x 12	21.7	75.0
	1600	1.6	SM250.80D	440	9 x 11	17.3	63.8
	1600	2.5	SM250.80D	440	9 x 11	27.1	79.1
2:1	800	1.6	SM250.45B	600	4 x 10	10.5	30.7
	1000	1.6	SM250.45B	640	2 x 14	9.8	30.8
	1000	2.5	SM250.45B	320	6 x 8	19.5	45.7
	1250	2.5	SM250.45B	400	5 x 10	25.3	63.9
	1600	1.0	SM250.45B	320	10 x 8	12.6	37.7
	1600	1.6	SM250.60B	320	10 x 8	11.4	30.1
	1600	2.5	SM250.60B	500	5 x 11	11.3	38.1
	1600	4.0	SM250.80D	520	6 x 11	38.8	95.1
	1600	1.0	SM250.60B	600	7 x 10	11.6	46.9
	1600	1.0	SM250.80D	640	6 x 12	12.1	50.4
	1600	1.6	SM250.60B	640	3 x 16	15.6	41.8
	2000	1.6	SM250.45B	320	10 x 8	22.1	59.2
	2000	1.6	SM250.60B	400	8 x 10	22.9	60.8
	2000	2.5	SM250.80D	440	9 x 11	43.4	112.8
	4:1	3000	1.0	SM250.45B	400	6 x 10	21.5
4000		1.0	SM250.80D	440	8 x 11	31.6	81.6
4500		1.0	SM250.80D	440	10 x 10	34.8	90.0
6000		1.0	SM250.80D-FB	440	10 x 11	43.0	141.9

ZAtop Gearless elevator machine

SM250.100C



Synchronous motor actuated by permanent magnets and according to the provisions of the Lift Directive 2014/33/EU

Drive

- NdFeB magnets
- For fast elevators of up to 4 m/s
- Noise emissions: < 50 dB(A)
- Insulation class F with temperature monitoring

Brake system

- Safety component according to the Lift Directive 2014/33/EU
- Separately activated brake circuits
- Deployable as an element of the ascending car overspeed protection means
- Deployable as part of the protection against unintended car movement

Motor cables	Page 108
Machine frames	Page 56
Deflection pulleys	Page 66
ZAlift	Page 70

Technical data

SM250.100C

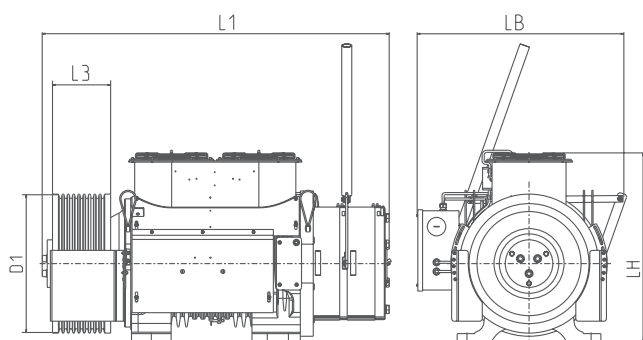

Motor type	Nominal torque Nm	Max. axle load kg	Nominal speed min ⁻¹	Rated output power kW	L1 mm	LH mm	LB mm	D1 mm	L3 mm	Weight kg
SM250.100C	2100...2650	13000	78...312	22.0...69.0	1313	729	794	450	282	1250
								500	220	
								520	220	



Scope of delivery and options

SM250	Standard	Options
Motor	Gearless elevator machine	-
Traction sheave	See D1	-
Brake	Certified brake system	Mechanical hand release
Brake monitoring	Microswitch	Inductive proximity switches
Motor cable	-	5 m, 10 m, 15 m, 20 m, 25 m, halogen free
Absolute encoder type Heidenhain	ECN 1313 EnDat	ECN 1313 SSI, ERN 1387, ERN 1326
Rope guard	2 pieces	3. rope guard
Temperature monitoring	PTC thermistor	KTY thermistor
Cooling	Surface cooling	Forced ventilation

Resulting rope force

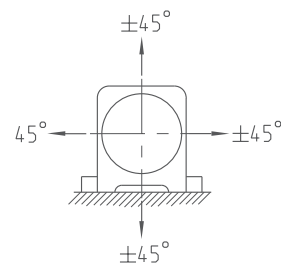

wit lateral form lock support

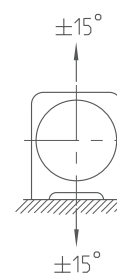

without lateral form lock support

Example configurations

Other configurations, also outside of the examples listed below, are possible. Our calculation software ZAlift is available to you for fast and convenient calculation of your elevator machine.

Suspension	Max. payload kg	Speed m/s	Motor type	Traction sheave mm	Rope Number x Ø mm	Motor power kW	Rated current A
1:1	1250	1.0	SM250.100C	450	8 x 11	10.0	52.9
	1250	3.5	SM250.100C	450	8 x 11	26.5	80.2
	1350	1.0	SM250.100C	520	6 x 13	8.1	49.5
	1350	3.0	SM250.100C	520	6 x 13	24.4	65.5
	1600	1.0	SM250.100C	450	9 x 11	12.4	65.4
	1600	3.0	SM250.100C	450	9 x 11	28.7	79.7
2:1	1800	1.0	SM250.100C	450	10 x 11	12.2	64.0
	2000	1.0	SM250.100C	500	6 x 12	17.1	50.0
	2000	4.0	SM250.100C	500	6 x 12	49.0	113.7
	2500	1.0	SM250.100C	500	7 x 11	20.0	58.4
	2500	2.5	SM250.100C	500	7 x 11	50.0	116.6
	3500	1.0	SM250.100C	450	11 x 11	24.8	86.4
4:1	3500	1.6	SM250.100C	450	11 x 11	39.7	103.3
	4000	1.0	SM250.100C	520	5 x 13	34.0	104.2
	4000	1.6	SM250.100C	520	5 x 13	49.3	124.0
	5500	1.0	SM250.100C	500	9 x 11	40.5	119.4
	5500	1.2	SM250.100C	500	9 x 11	50.1	109.0
6500	1.0	SM250.100C	450	10 x 11	47.4	125.7	





Gearless elevator machine ZAsyn

Product overview

Information	Page 38
ZAsyn SM700	Page 40
ZAsyn SM860	Page 42

Information

ZAtop

ZAsyn

ZAdisc

VFD

System components motors

Control technology

System components control technology

Appendix



ZAsyn Gearless elevator machine

General information

The flat elevator machine for elevators with and without a machine room

Properties

- Gearless synchronous motor actuated by NdFeB permanent magnets
- External rotor motor
- According to the provisions of the Lift Directive 2014/33/EU
- Very flat design for optimum shaft dimensions
- Optimised for easy installation in the shaft
- High efficiency
- Noise emissions < 50 dB(A)
- Insulation class F (155°C) with temperature monitoring via PTC thermistor
- Travel speeds of up to 3.0 m/s
- Rope diameter of 8.0 mm to 16.0 mm
- Traction sheaves:
 - Replaceable
 - Diameter of 400 mm to 680 mm
- Motor brake:
 - Safety component according to Lift Directive 2014/33/EU
 - Separately actuated brake circuits
 - Deployable as an element of the ascending car overspeed protection means
 - Deployable as part of the protection against unintended car movement
 - Mechanical hand release (optional)
- Can be equipped with conventional encoder systems (e.g. EnDat, SSI, SinCos)
- Optimum package solution with ZAdyn frequency inverter from ZIEHL-ABEGG

A glimpse inside

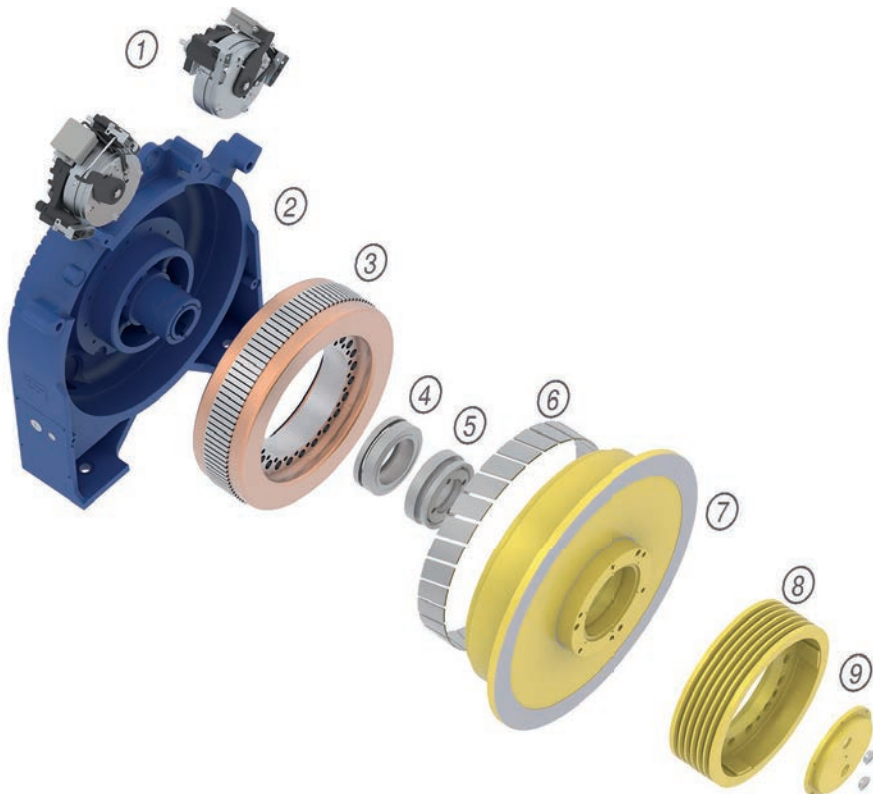

- ① Brake
- ② Housing
- ③ Stator lamination
- ④ Shaft seal ring
- ⑤ Shaft bearing
- ⑥ Magnets
- ⑦ Rotor
- ⑧ Traction sheave
- ⑨ Traction sheave bracket



Product portfolio ZAsyn

ZIEHL-ABEGG offers you the most comprehensive range of gearless elevator machines with the greatest flexibility and variability.

Suspension	Rated load max. kg	Traction sheave diameter mm	Axle load kg	ZAsyn		Page
2:1	1200	400	3000	SM700.09		Page 40
	1600	400	3600	SM700		Page 40
	2500	480...680	8000	SM860		Page 42

- Information
- ZAtop
- ZAsyn
- ZAdisc
- VFD
- System components motors
- Control technology
- System components control technology
- Appendix

ZAsyn Gearless elevator machine

SM700



Synchronous motor actuated by permanent magnets and according to the provisions of the Lift Directive 2014/33/EU

Drive

- NdFeB magnets
- Installation depth of ≤ 336 mm makes it perfect for mounting on the wall of the elevator shaft
- Noise emissions: < 50 dB(A)
- Insulation class F with temperature monitoring

Brake system

- Safety component according to the Lift Directive 2014/33/EU
- Separately activated brake circuits
- Deployable as an element of the ascending car overspeed protection means
- Deployable as part of the protection against unintended car movement

Motor cables	Page 108
Deflection pulleys	Page 66
ZAlift	Page 70

Technical data

SM700.09AL-14AL

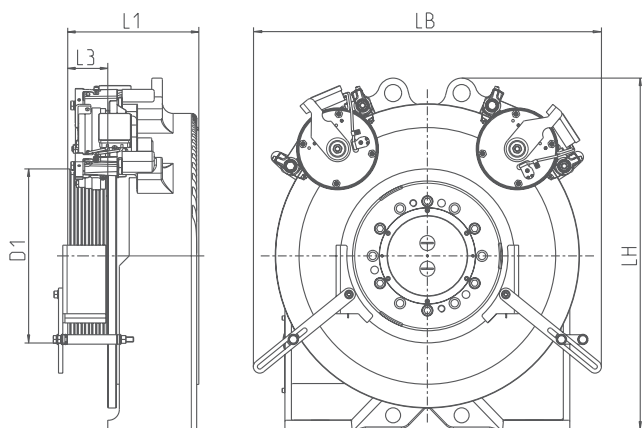

SM700.16AL(3)

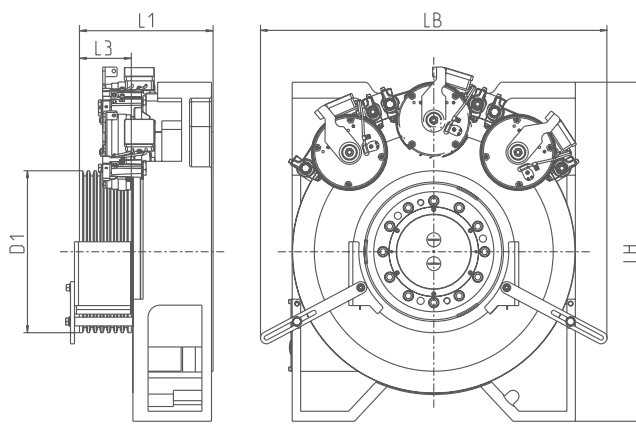

Motor type	Nominal torque Nm	Max. axle load kg	Nominal speed min ⁻¹	Rated output power kW	L1 mm	LH mm	LB mm	D1 mm	L3 mm	Weight kg
SM700.09AL	500	3000	60...96	3.0...5.0	306	821	813	400	60	530
SM700.12AL	750	3000	60...168	4.5...13.0	336				90	535
SM700.14AL	850	3000	60...240	5.5...17.5	366				120	540
SM700.16AL	1000	3600	60...240	6.5...20.0	296				850	870
				326	90	565				
				356	120	570				
				366	130	575				
SM700.16AL3	1150	3600	60...168	7.2...20.0	326	888	870	400	90	580
				356	120				595	
				366	130				605	



Scope of delivery and options

SM700	Standard	Options
Motor	Gearless elevator machine	-
Traction sheave	See D1	-
Brake	Certified brake system	Mechanical hand release
Brake monitoring	Microswitch	-
Motor cable	-	5 m, 10 m, 15 m, 20 m, 25 m, halogen free
Absolute encoder type Heidenhain	ECN 1313 EnDat	ECN 1313 SSI, ERN 1387
Rope guard	2 pieces	-
Temperature monitoring	PTC thermistor	KTY thermistor
Cooling	Surface cooling	-
Mounting	-	Console for wall mounting

Resulting rope force

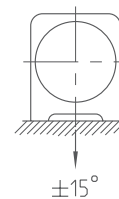

Example configurations

Other configurations, also outside of the examples listed below, are possible. Our calculation software ZAlift is available to you for fast and convenient calculation of your elevator machine.

Suspension	Max. payload kg	Speed m/s	Motor type	Traction sheave mm	Rope Number x Ø mm	Motor power kW	Rated current A
1:1	320	2.0	SM700.09AL	400	3 x 10	5.0	11.5
	630	3.0	SM700.14AL	400	5 x 10	14.0	33.5
	500	3.0	SM700.12AL	400	4 x 10	13.0	32.5
	675	2.0	SM700.16AL	400	6 x 10	10.0	25.0
	800	2.0	SM700.16AL3	400	7 x 10	11.6	29.0
2:1	675	1.0	SM700.09AL	400	3 x 10	5.0	12.2
	1000	1.6	SM700.12AL	400	4 x 10	12.0	29.0
	1000	2.0	SM700.14AL	400	5 x 10	17.0	40.5
	1000	2.5	SM700.14AL	400	5 x 10	17.5	43.0
	1200	2.0	SM700.14AL	400	6 x 10	17.0	40.6
	1250	2.5	SM700.16AL	400	6 x 10	20.0	50.0
	1350	2.0	SM700.16AL	400	6 x 10	18.0	50.0
	1500	1.6	SM700.16AL3	400	7 x 10	18.8	45.0
	1600	1.0	SM700.16AL3	400	7 x 10	11.6	29.0

Information

ZAtop

ZAsyn

ZAdisc

VFD

System components motors

Control technology

System components control technology

Appendix



ZAsyn Gearless elevator machine

SM860



Synchronous motor actuated by permanent magnets and according to the provisions of the Lift Directive 2014/33/EU

Drive

- NdFeB magnets
- Perfect for mounting in tight spaces
- Noise emissions: < 50 dB(A)
- Insulation class F with temperature monitoring

Brake system

- Safety component according to the Lift Directive 2014/33/EU
- Separately activated brake circuits
- Deployable as an element of the ascending car overspeed protection means
- Deployable as part of the protection against unintended car movement

Motor cables	Page 108
Deflection pulleys	Page 66
ZAlift	Page 70

Technical data

SM860.28AL

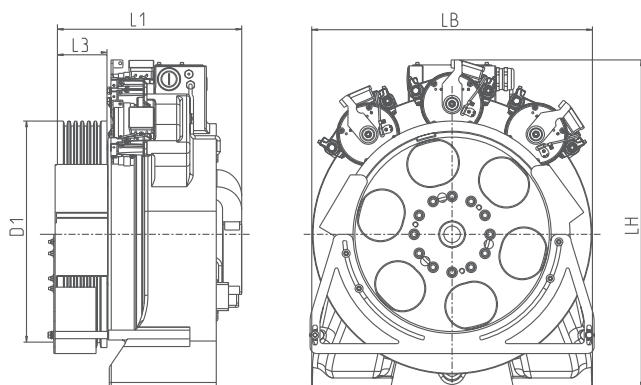

Motor type	Nominal torque	Max. axle load	Nominal speed	Rated output power	L1	LH	LB	D1	L3	Weight
	Nm	kg	min ⁻¹	kW	mm	mm	mm	mm	mm	kg
SM860.28AL	2200	8000	40...196	9.2...39.0	586	993	860	480	150	1004
								520		1010
								600		1027
								680		1050



Scope of delivery and options

SM860	Standard	Options
Motor	Gearless elevator machine	-
Traction sheave	See D1	-
Brake	Certified brake system	Mechanical hand release
Brake monitoring	Microswitch	-
Motor cable	-	5 m, 10 m, 15 m, 20 m, 25 m, halogen free
Absolute encoder type Heidenhain	ECN 1313 EnDat	ECN 1313 SSI, ERN 1387
Rope guard	2 pieces	-
Temperature monitoring	PTC thermistor	KTY thermistor
Cooling	Forced ventilation	-

Resulting rope force

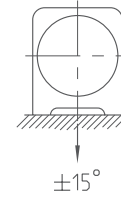

Example configurations

Other configurations, also outside of the examples listed below, are possible. Our calculation software ZAlift is available to you for fast and convenient calculation of your elevator machine.

Suspension	Max. payload kg	Speed m/s	Motor type	Traction sheave mm	Rope Number x Ø mm	Motor power kW	Rated current A
1:1	1000	2.5	SM860.28AL	600	5 x 13	22.0	52.7
	1200	3.0	SM860.28AL	480	7 x 12	30.0	55.0
	1250	2.0	SM860.28AL	480	7 x 12	22.0	53.5
2:1	2000	2.5	SM860.28AL	600	4 x 13	39.0	78.1
	2500	1.0	SM860.28AL	480	7 x 12	22.0	53.5
	2500	2.5	SM860.28AL	480	6 x 12	39.0	77.8

- Information
- ZAtop
- ZAsyn
- ZAdisc
- VFD
- System components motors
- Control technology
- System components control technology
- Appendix

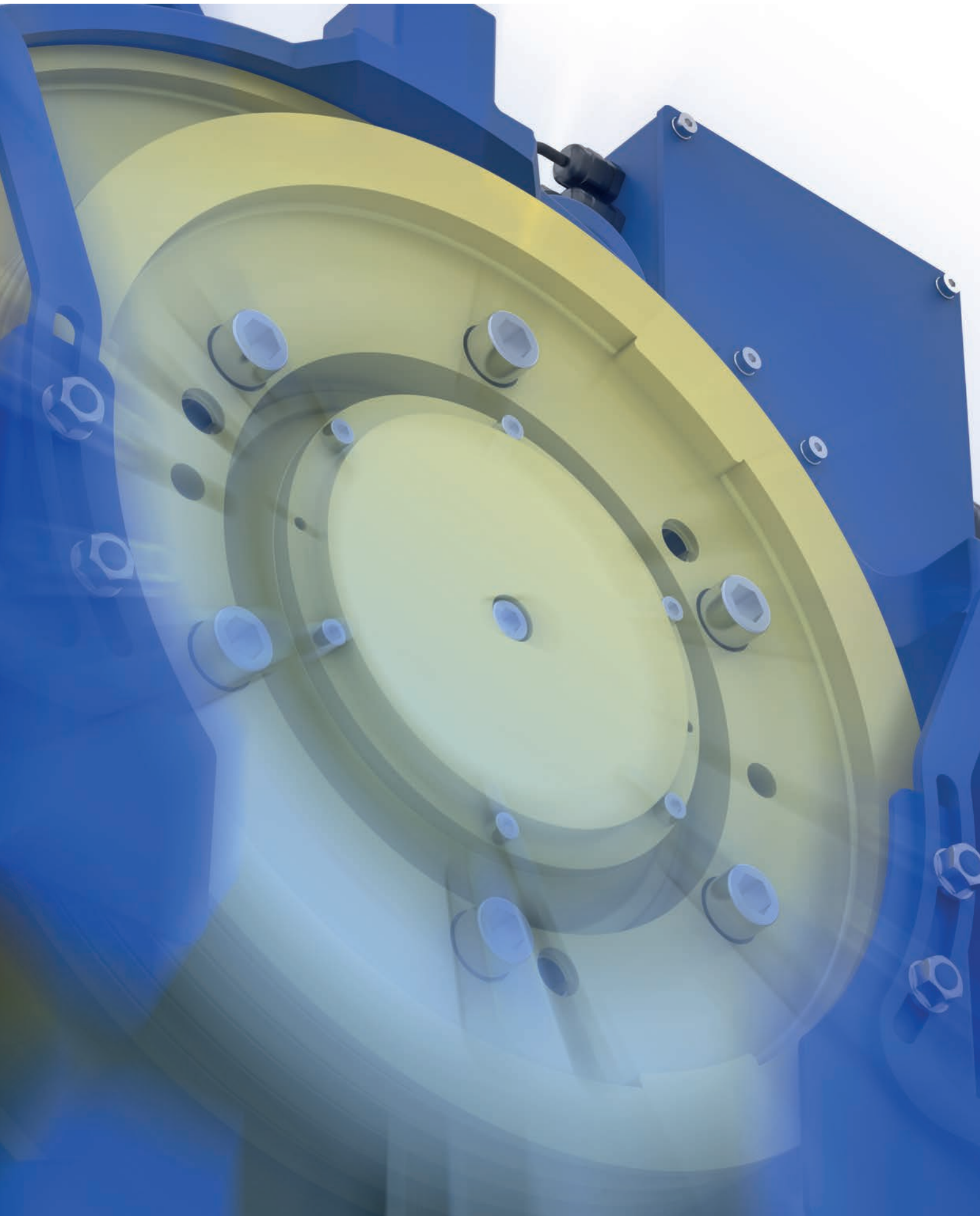

Gearless elevator machine ZAdisc

Product overview

Information Page 46

ZAdisc SL506 / 510 Page 48

Information

ZAtop

ZAsyn

ZAdisc

VFD

System compo-
nents motors

Control
technology

System com-
ponents control
technology

Appendix



ZAdisc Gearless elevator machine

General information

The flat elevator machine for elevators with and without a machine room

Properties

- Gearless synchronous motor actuated by NdFeB permanent magnets
- Disc rotor motor
- According to the provisions of the Lift Directive 2014/33/EU
- Very flat design for optimum shaft dimensions
- Optimised for fixing at the guide rail
- High efficiency
- Noise emissions <50 dB(A)
- Insulation class F (155°C) with temperature monitoring via PTC thermistor
- Travel speeds of up to 1.6 m/s
- Rope diameter of 8.0 mm to 12.0 mm
- Traction sheaves:
 - Replaceable
 - Diameter of 400 mm to 480 mm
- Motor brake:
 - Safety component according to Lift Directive 2014/33/EU
 - Separately actuated brake circuits
 - Deployable as an element of the ascending car overspeed protection means
 - Deployable as part of the protection against unintended car movement
- Can be equipped with conventional encoder systems (e.g. EnDat, SSI, SinCos)
- Optimum package solution with ZAdyn frequency inverter from ZIEHL-ABEGG

A glimpse inside

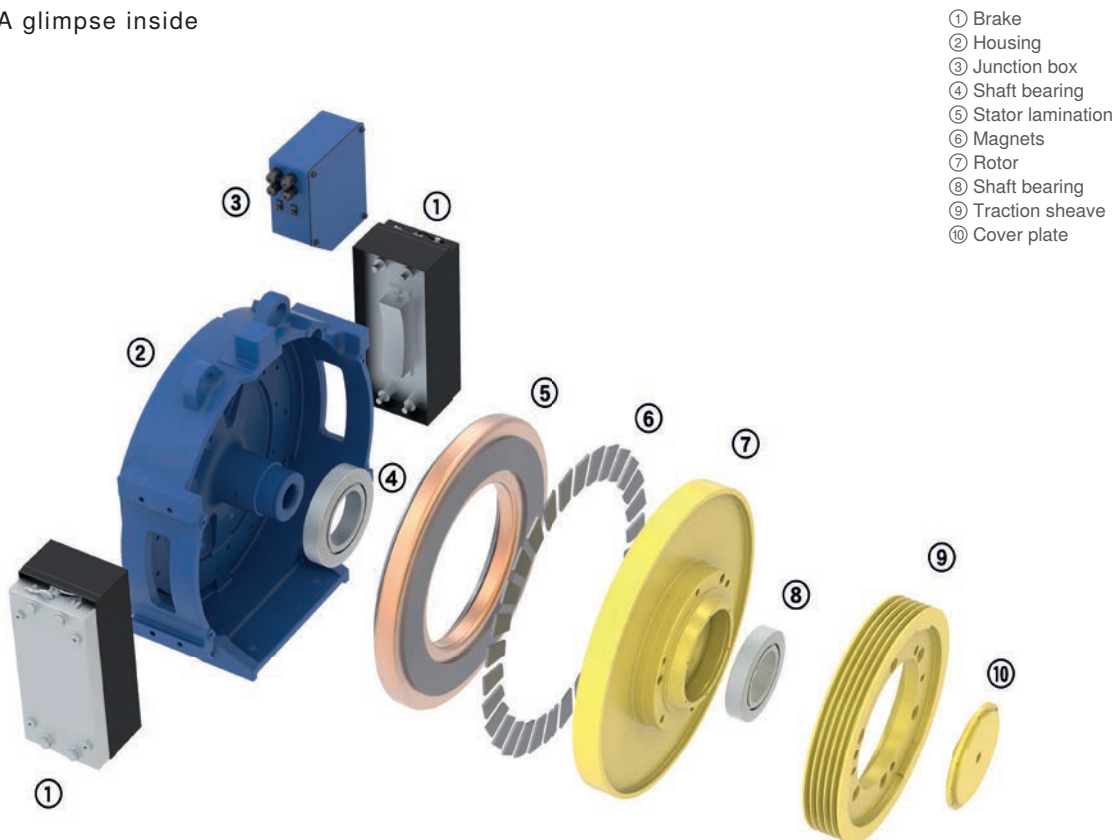

Product portfolio ZAdisc

With the gearless elevator machines ZAdisc ZIEHL-ABEGG offers you the greatest flexibility and variability.

Suspension	Rated load max. kg	Traction sheave diameter mm	Axle load kg	ZAdisc	Image	Page
2:1	675	400	1800	SL506		Page 48
	1125	480	2400	SL510		Page 48

Information

ZAtop

ZAsyn

ZAdisc

VFD

System components motors

Control technology

System components control technology

Appendix

ZAdisc Gearless elevator machine

SL506 / 510

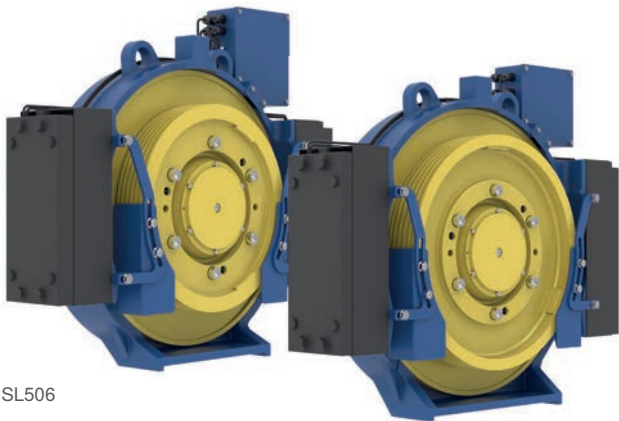

SL506

SL510

Synchronous motor actuated by permanent magnets and according to the provisions of the Lift Directive 2014/33/EU

Drive

- NdFeB magnets
- Installation depth ≤ 200 mm
- Optimised for attaching to the guide rail
- Noise emissions: < 50 dB(A)
- Insulation class F with temperature monitoring

Brake system

- Safety component according to the Lift Directive 2014/33/EU
- Separately activated brake circuits
- Deployable as an element of the ascending car overspeed protection means
- Deployable as part of the protection against unintended car movement

Motor cables	Page 108
Deflection pulleys	Page 66
ZAlift	Page 70

Technical data

SL506 / SL510

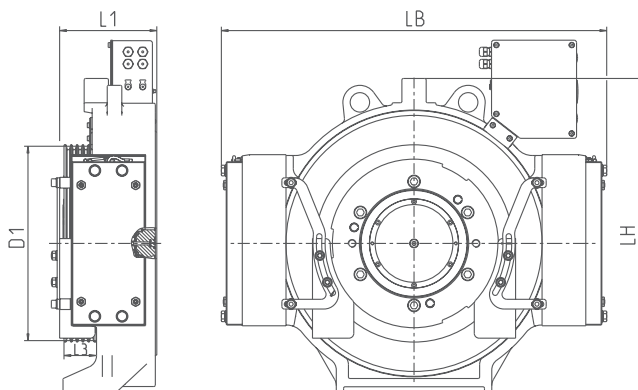

Motor type	Nominal torque Nm	Max. axle load kg	Nominal speed min ⁻¹	Rated output power kW	L1 mm	LH mm	LB mm	D1 mm	L3 mm	Weight kg
SL506	560	1800	240	5.0...8.2	193	721	793	400	66	310
SL510	960	2400	200	7.4...18.0	193	770	854	480	76	380



Scope of delivery and options

SL506 / SL510	Standard	Options
Motor	Gearless elevator machine	-
Traction sheave	See D1	-
Brake	Certified brake system	-
Brake monitoring	Microswitch	Inductive proximity switches
Motor cable	-	5 m, 10 m, 15 m, 20 m, 25 m, halogen free
Absolute encoder type Heidenhain	ECN 1313 EnDat	ECN 1313 SSI, ERN 1387
Rope guard	2 pieces	3. rope guard
Temperature monitoring	PTC thermistor	KTY thermistor
Cooling	Surface cooling	-
Mounting	-	Mounting bracket and bracket for rail mounting

Resulting rope force

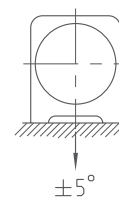

Example configurations

Other configurations, also outside of the examples listed below, are possible. Our calculation software ZAlift is available to you for fast and convenient calculation of your elevator machine.

Suspension	Max. payload kg	Speed m/s	Motor type	Traction sheave mm	Rope Number x Ø mm	Motor power kW	Rated current A
2:1	480	1.0	SL506.12	400	3 x 8	3.2	11.0
	480	1.6	SL506.12	400	3 x 8	5.5	18.4
	630	1.0	SL506.12	400	3 x 10	4.4	14.8
	675	1.6	SL506.12	400	3 x 10	7.9	26.3
	1000	1.6	SL510.17	480	4 x 10	11.4	41.1
	1050	1.0	SL510.17	480	4 x 10	7.0	26.9
	1125	1.0	SL510.17	480	5 x 8	7.0	28.0

Information

ZAtop

ZAsyn

ZAdisc

VFD

System components motors

Control technology

System components control technology

Appendix

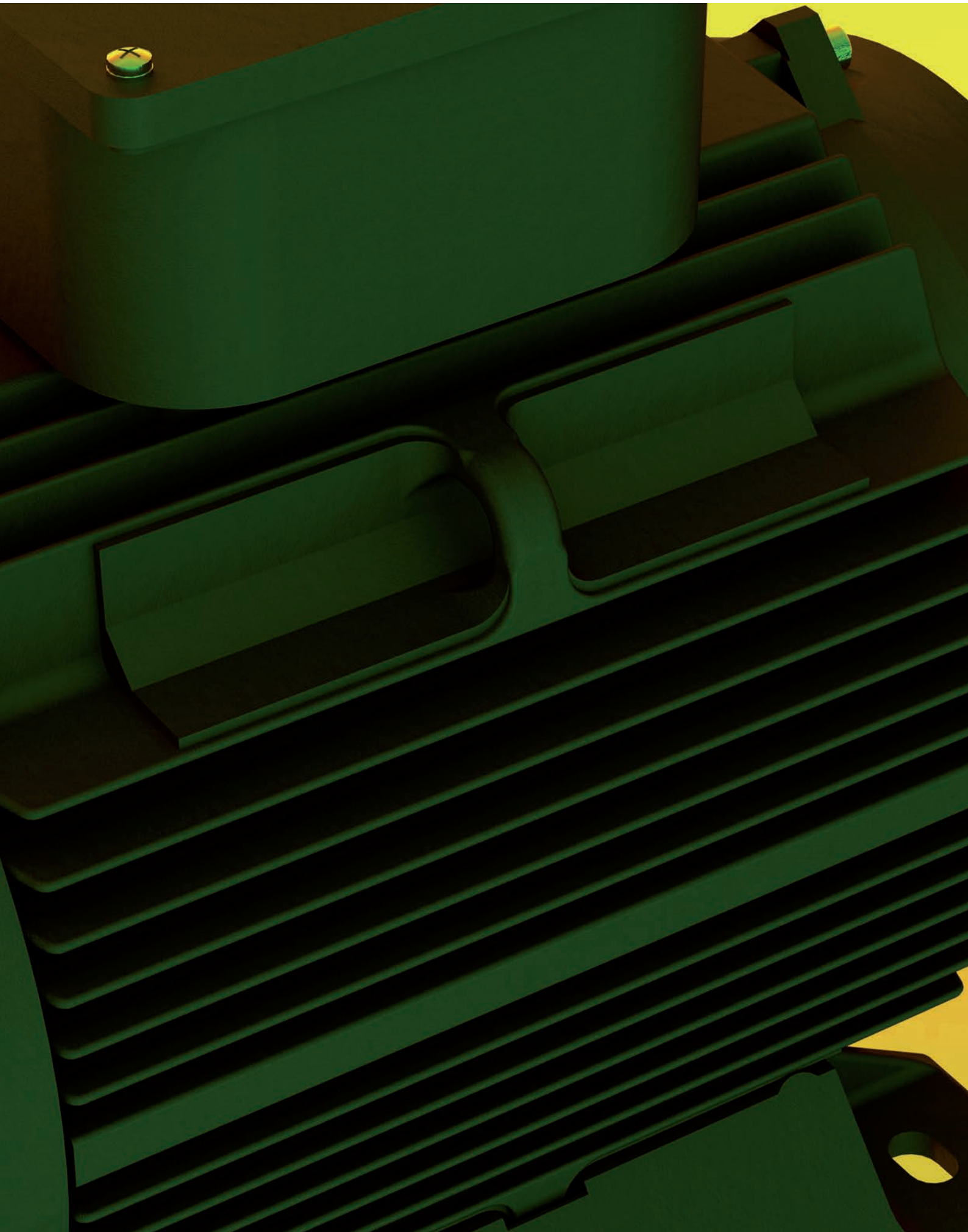

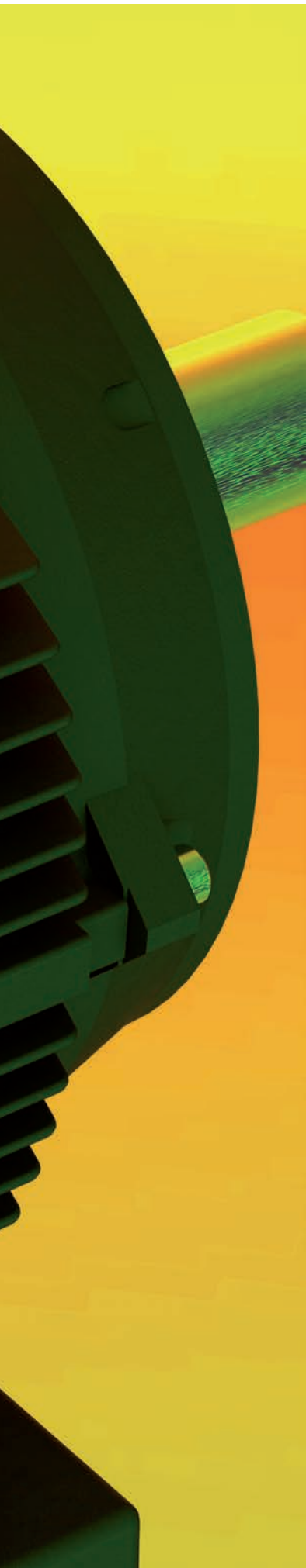

Motors VFD

Motors VFD

Frequency controlled elevator motors



Description

- Surface-cooled asynchronous motor
- Especially for elevator machines with gearbox
- High efficiency
- Frequency controllable
- Optimised for low-noise operation
- Operating voltage 360 V AC
- Design IM B3

Options

- Hand wheel with low moment of inertia
- Incremental encoder in different signal forms and resolutions

Motor cables

Page 108

Technical data

Motor type	Rated frequency	Rated power	Rated torque	Rated current	Rated speed
	Hz	kW	Nm	A	min ⁻¹
VFD132M-4	38	4.0	37	9.7	1090
	50	5.5		13.0	1453
	66	7.5		17.5	1934
VFD132MA-4	38	5.5	50	13.1	1093
	50	7.5		17.8	1451
	66	10.0		22.7	1933
VFD132MB-4	38	6.8	61	15.8	1089
	50	9.2		21.0	1448
	66	12.0		27.4	1929
VFD160LA-4	38	8.5	72	18.0	1113
	50	11.0		24.0	1469
	66	14.5		31.0	1953
VFD160LB-4	38	11.5	100	24.0	1113
	50	15.0		32.5	1471
	66	20.0		42.0	1953
VFD180L-4	38	16.5	144	34.5	1115
	50	22.0		46.0	1476
	66	29.0		60.0	1955
VFD200L-4	38	23.0	197	47.0	1122
	50	30.0		64.0	1479
	66	40.0		81.0	1962
VFD225M-4	38	28.0	242	60.0	1120
	50	37.0		79.0	1468
	66	50.0		104.0	1960
VFD225M-4	38	34.0	292	70.0	1119
	50	45.0		91.0	1483
	60	60.0		121.0	1959
VFD250M-4	38	42.0	357	85.0	1119
	50	55.0		116.0	1480
	66	73		146.0	1959

Dimensions mm

VFD132..., VFD160...

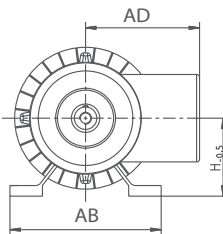
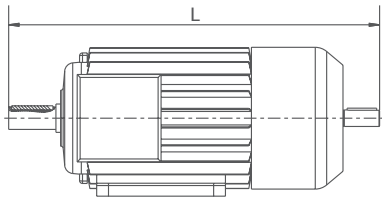

VFD180..., VFD200..., VFD225..., VFD250..., VFD280...

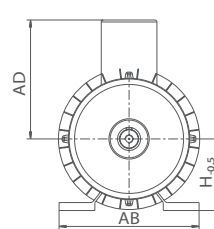
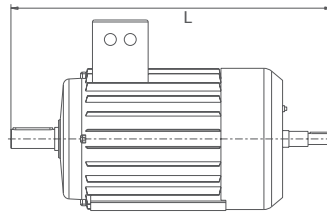

Motor type	D mm	L mm	AB mm	AD mm	H mm
VFD132M-4	38	613	256	193	132
VFD132MA-4					
VFD132MB-4		628			
VFD160LA-4	42	742	320	250	160
VFD160LB-4					
VFD180L-4	48	807	352	299	180
VFD200L-4	55	857	403	299	200
VFD225M-4	60	925	440	238	225
VFD250M-4	65	1004	490	361	250
VFD280S-4	75	1054	536	361	280
VFD280M-4					

- Information
- ZAtop
- ZAsyn
- ZAdisc
- VFD
- System compo-nents motors
- Control technology
- System com-ponents control technology
- Appendix

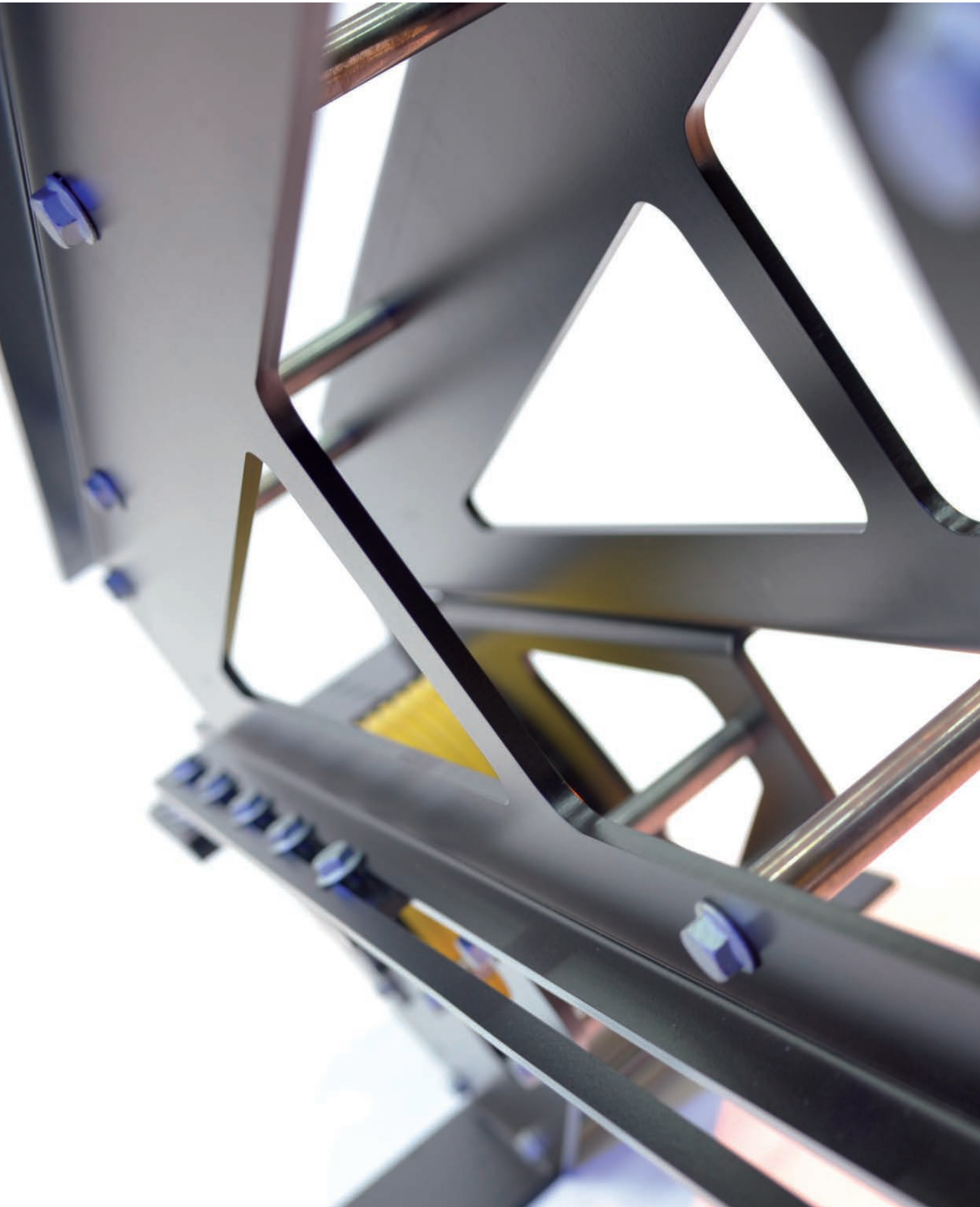

System components

Product overview

ZAframe MH4000	Page 56
ZAframe MH6000	Page 57
ZAframe MF2800 / MF4000 / MF6000	Page 58
ZAframe MS4000 / MS8000	Page 60
ZAframe MD13000	Page 62
ZAframe MK2800	Page 63
ZAframe MN3000	Page 64
Adapter plates	Page 65
Deflection pulleys	Page 66
Forced ventilation ZAtop	Page 67
Oil heating motors	Page 68
Tool set	Page 69
ZAlift	Page 70

Information

ZAtop

ZAsyn

ZAdisc

VFD

System components motors

Control technology

System components control technology

Appendix

ZAframe MH4000

Elevated frame for ZAtop SM160.30B - SM200.45D



Description

- Elevated frame with one deflection pulley
- Screwed sheet metal design
- Static load: up to 4,000 kg
- Typical payload: 630 kg to 1,600 kg
- Rope distance (ASL): 400 mm to 1,330 mm, adjustable in 40 mm steps
- Traction sheave: 160 mm to 500 mm
- Deflection pulley: 160 mm to 520 mm
- Version as illustrated or motor turned through 180°
- Can be delivered assembled or unassembled

Scope of delivery

- Frame with fastening material
- Deflection pulley with fastening material
- Insulating elements

Options

- Nip guard
- Different traction sheaves and deflection pulleys

MH4000					
Motor type	Traction sheave D1 mm	Deflection pulley mm	ASL mm	Max. static load kg	Article no.
SM160.30B/S SM160.40B/S	240	240	420 - 1140	4000	70028156
SM200.15C/20C/30C	240	240	420 - 1140		70028158
SM200.15C/20C/30C	320	320	500 - 1220		70028161
SM200.15C/20C/30C	400	400	500 - 1260		70028162
SM200.40D/45D	160	160	420 - 1060		70028159
SM200.40D/45D	240	240	420 - 1140		70028160
SM200.40D/45D	320	320	500 - 1220		70028163
SM200.40D/45D	400	400	500 - 1260		70028164
SM200.40D/45D	500	520	500 - 1280	70028166	

Dimensions mm

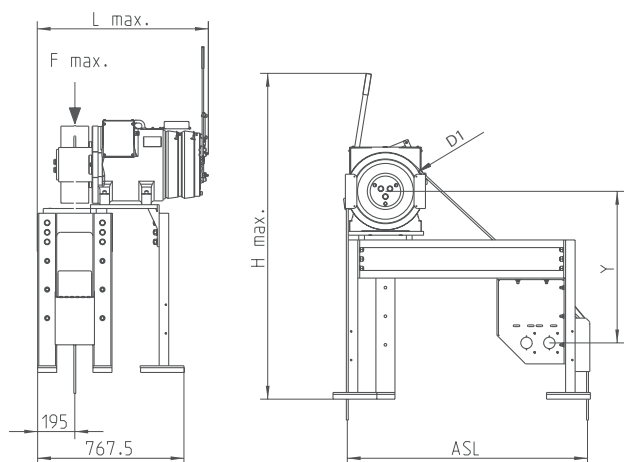

Motor type	Y mm	H max. mm	L max. mm
SM160.30B/S SM160.40B/S	774	1492	810
SM200.15C/20C/30C	680	1323	763
SM200.40D/45D	797	2045	879

ZAframe MH6000

Elevated frame for ZAtop SM225.60B - SM250.80D



Description

- Elevated frame with one deflection pulley
- Screwed sheet metal design
- Static load: up to 6,000 kg
- Typical payload: 630 kg to 3,000 kg
- Rope distance (ASL): 520 mm to 1,045 mm
- Traction sheave: 400 mm to 640 mm
- Deflection pulley: 400 mm to 520 mm
- Version as illustrated or motor turned through 180°

Scope of delivery

- Frame with fastening material
- Deflection pulley with fastening material
- Insulating elements

Options

- Nip guard
- Frame
- Different traction sheaves and deflection pulleys

Base frame

Article no. 02014254-M

MH6000						
Motor type	Traction sheave D1 mm	Deflection pulley D2 mm	ASL mm	Max. static load kg	Article no. adaptation left	Article no. adaptation right
SM225.60B	400	400	520 - 925	6000	70029683	70027828
	500	520	630 - 975		70029684	70027848
	520	520	640 - 985		70029684	70027848
	600	520	660 - 1025		70029685	70027849
	640	520	680 - 1045		70029685	70027849
SM250.60B	400	400	520 - 925		70029683	70027828
	500	520	630 - 975		70029684	70027848
	520	520	640 - 985		70029684	70027848
	600	520	660 - 1025		70029685	70027849
	640	520	680 - 1045		70029685	70027849
SM250.80D	440	400	540 - 945		70029683	70027828
	520	520	640 - 985		70029684	70027848
	640	520	680 - 1045		70029685	70027849

Dimensions mm

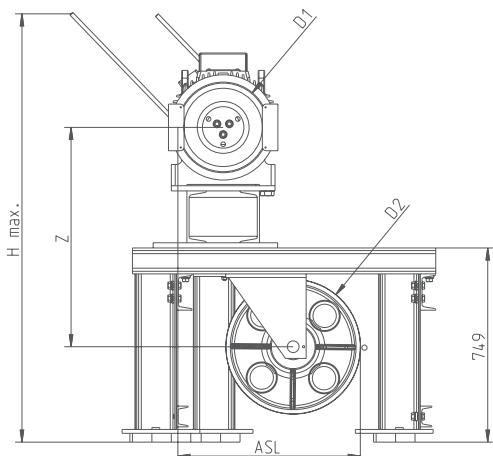

Motor type	D1 mm	D2 mm	Z mm	H max. mm
SM225.60B	400	400	846	1817
	500/520	520	896	1867
	600/640	520	946	1917
SM250.60B	400	400	846	1952
	500/520	520	896	2002
	600/640	520	946	2052
SM250.80D	440	400	858	2088
	500/520	520	858	2088
	600/640	520	938	2138

ZAframe MF2800 + MF4000

Flat frame for ZAtop SM160.30B - SM200.45D

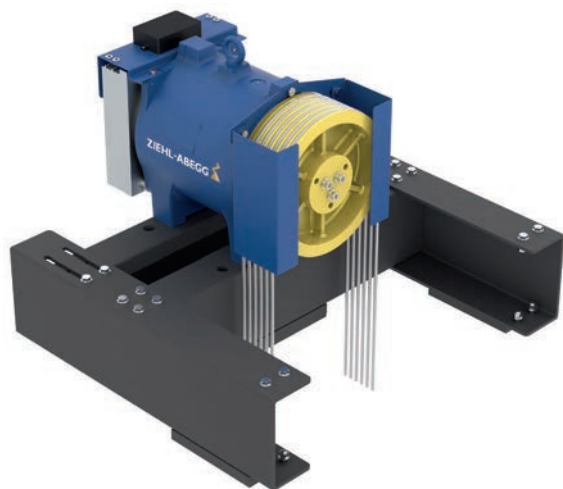

Description

- Flat frame
- Screwed sheet metal design
- Static load: up to 4,000 kg
- Typical payload: 630 kg to 1,600 kg
- Can be delivered assembled or unassembled

Scope of delivery

- Frame with fastening material
- Insulating elements

MF2800 / MF4000			
Motor type	Traction sheave D1 mm	Max. static load kg	Article no.
SM160.30B/S	160 - 240	2800	70028278
SM160.40B/S	200 - 240		
SM190.15/23	160 - 450		
SM200.15C/20C/30C			
SM200.40D/45D	160 - 500	4000	70028279

Dimensions mm

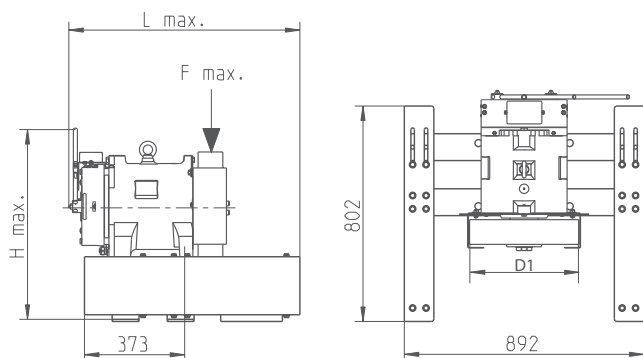

Motor type	H max. mm	L max. mm
SM160.30B/S	853	896
SM160.40B/S		
SM190.15/23	681	777
SM200.15C/20C/30C	860	833

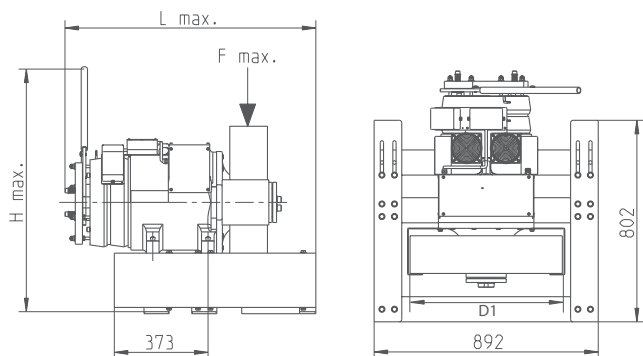

Motor type	H max. mm	L max. mm
SM200.40D/45D	1406	1117

ZAframe MF6000

Flat frame for ZAtop SM225.60B - SM250.80D



Description

- Flat frame
- Screwed sheet metal design
- Static load: up to 6,000 kg
- Typical payload: 1,000 kg to 3,600 kg
- Can be delivered assembled or unassembled

Scope of delivery

- Frame with fastening material
- Insulating elements

Information

ZAtop

ZAsyn

ZAdisc

VFD

System components motors

Control technology

System components control technology

Appendix

MF6000			
Motor type	Traction sheave D1 mm	Max. static load kg	Article no.
SM225.60B	320	6000	02010208
SM250.60B			
SM225.60B	400		
SM250.60B			
SM250.80D	440		
SM225.60B	500		
SM250.60B			
SM250.80D	520		
SM225.60B	600		
SM250.60B			
SM250.80D	640		

Dimensions mm

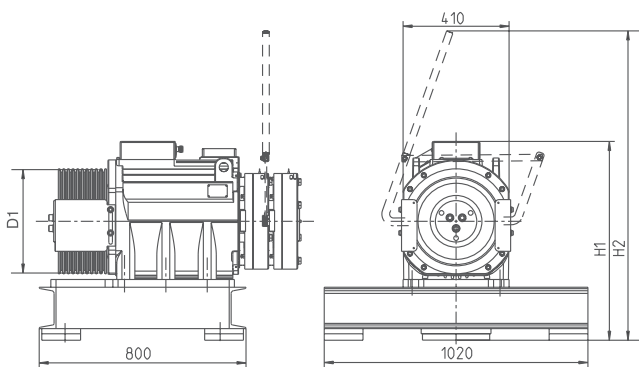

Motor type	D1 mm	H1 mm	H2 mm
SM225.60B	320	769	1197
	400	769	1197
	500	819	1247
	600	869	1297
SM250.60B	320	769	1197
	400	769	1197
	500	819	1247
	600	869	1297
SM250.80D	440	880	1334
	520	880	1334
	640	930	1384

ZAframe MS4000

Frame S-wrap for ZAtop SM160 - SM200.45D

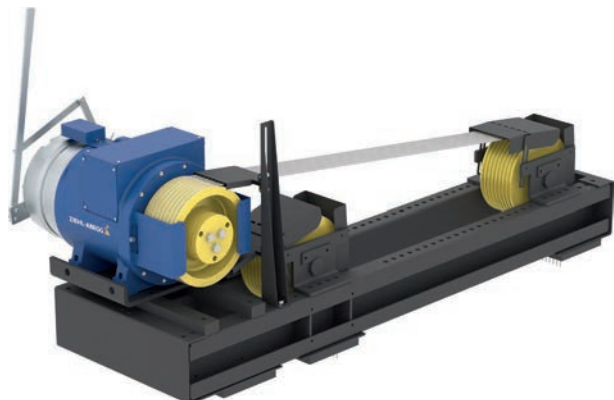

Description

- Frame with two deflection pulleys
- Screwed sheet metal design
- Static load: up to 4,000 kg
- Typical payload: 630 kg to 1,600 kg
- Rope distance (ASL): 360 mm to 1,200 mm, adjustable in 40 mm steps
- Traction sheave: 200 mm to 400 mm
- Deflection pulley: 240 mm to 400 mm
- Version as illustrated or motor turned through 180°
- Can be delivered assembled or unassembled

Scope of delivery

- Frame with fastening material
- Deflection pulley with fastening material
- Insulating elements

Options

- Nip guard
- Different traction sheaves and deflection pulleys

MS4000				
Motor type	Traction sheave D1 mm	ASL mm	Max. static load kg	Article no.
SM160.30B/S SM160.40B/S	240	400 - 1200	4000	70028387
SM200.15C/20C/30C	240	400 - 1200		70028388
SM200.15C/20C/30C	320	440 - 1200		70028390
	400	520 - 1200		
SM200.40D/45D	240	400 - 1200		70028389
SM200.40D/45D	320	440 - 1200		70028391
	400	520 - 1200		

Dimensions mm

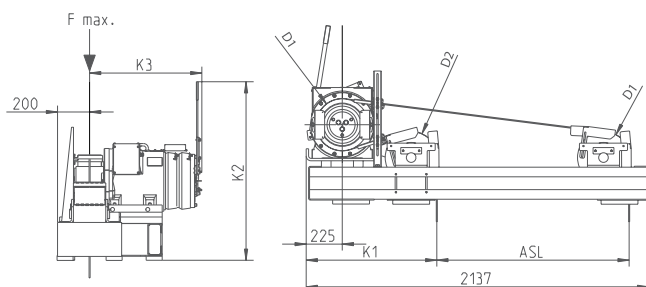

Motor type	D1 mm	D2 mm	K1 mm	K2 mm	K3 mm
SM160.30B/S SM160.40B/S	240	240	775	897	540
SM200.15C/20C/30C	240	240	775	877	535
SM200.40D/45D	240	240	775	1450	810
SM200.15C/20C/30C	320	320	815	877	535
	400	400	855	877	535
SM200.40D/45D	320	320	815	1450	810
	400	400	855	1450	810

ZAframe MS8000

Frame S-wrap for ZAtop SM225.60B - 250.80D

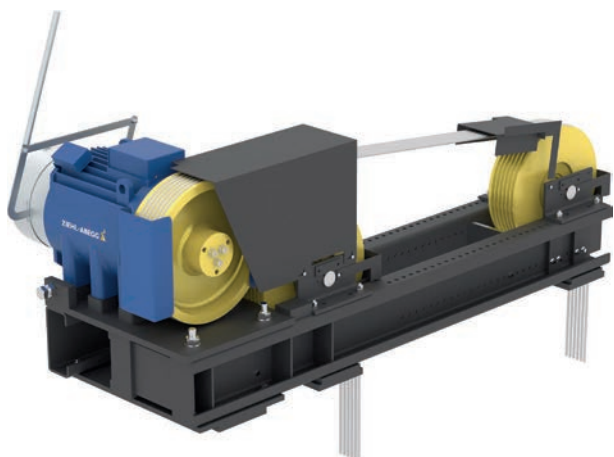

Description

- Frame with two deflection pulleys
- Screwed sheet metal design
- Static load: up to 8,000 kg
- Typical payload: 1,000 kg to 3,000 kg
- Rope distance (ASL): 400 mm to 1,400 mm, adjustable in 40 mm steps
- Traction sheave: 320 mm to 520 mm
- Deflection pulley: 320 mm to 520 mm
- Version as illustrated or motor turned through 180°
- Can be delivered assembled or unassembled

Scope of delivery

- Frame with fastening material
- Deflection pulley with fastening material
- Insulating elements

Options

- Nip guard
- Different traction sheaves and deflection pulleys

MS8000					
Motor type	Traction sheave D1 mm	Deflection pulley D2 mm	ASL mm	Max. static load kg	Article no.
SM225.60B	320	320	400 - 1400	8000	70028057 70028307
SM225.60B	400	400	440 - 1400		70028058 70028302
SM225.60B	520	520	560 - 1400		70028059 70028062
SM250.60B	320	320	400 - 1400		70028060 70028308
SM250.60B	400	400	440 - 1400		70028058 70028302
SM250.60B	520	520	560 - 1400		70028061 70028062
SM250.80D	440	400	560 - 1400		70028063 70028309
SM250.80D	520	520	560 - 1400		70028064 70028350

Dimensions mm

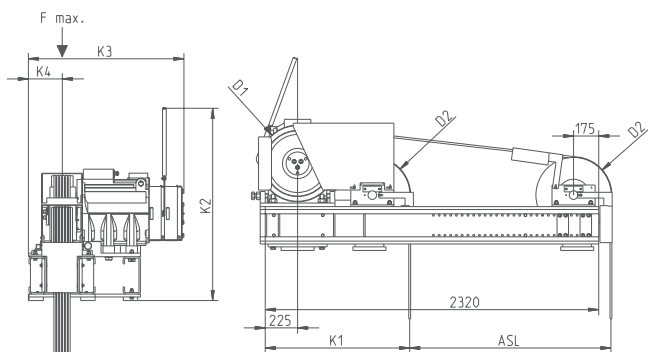

Motor type	D1 mm	K1 mm	K2 mm	K3 mm	K4 mm
SM225.60B	320	905	1158	1050	236
	400	945	1158	1050	236
	520	1005	1158	1050	236
SM250.60B	320	905	1345	1250	236
	400	945	1345	1250	236
	520	1005	1345	1250	236
SM250.80D	440/520	1005	1430	1230	229

ZAframe MD13000

Frame for double wrap for ZAtop SM250.100C



Description

- Frame with one deflection pulley
- Welded / screwed construction
- Static load: up to 13,000 kg
- Typical payload: 1,000 kg to 3,500 kg
- Rope distance (ASL): 1,020 mm to 1,455 mm, adjustable in 50 mm steps
- Traction sheave: 450 mm to 520 mm
- Deflection pulley: 520 mm
- Version as illustrated or motor turned through 180°

Scope of delivery

- Frame with fastening material
- Deflection pulley with fastening material
- Nip guard
- Rope guard
- Insulating elements

MD13000					
Motor type	Traction sheave D1 mm	Max. static load kg	Deflection pulley mm	ASL mm	Article no.
SM250.100C	450	13000	520	1020 - 1420	70027456-M
SM250.100C	500			1045 - 1445	70027457-M
SM250.100C	520			1055 - 1455	

Dimensions mm

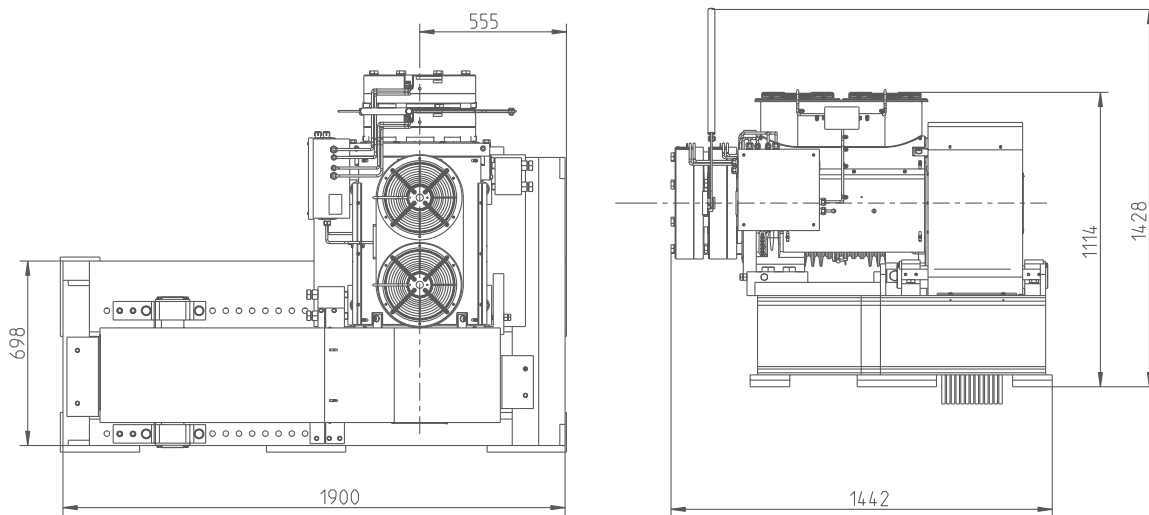

ZAframe MK2800

Frame for ZAtop SM132 - SM200.30C

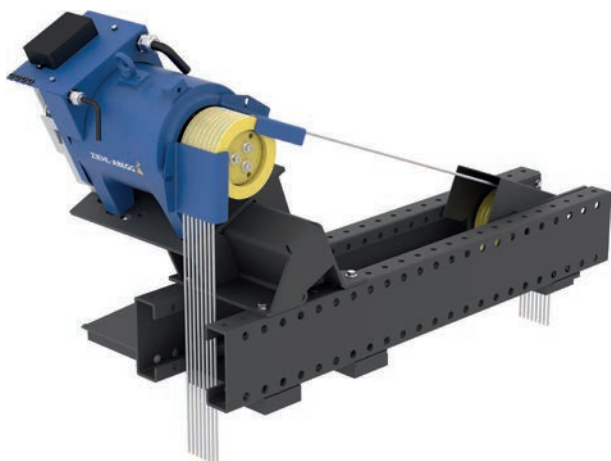

Description

- Frame with one deflection pulley
- Screwed sheet metal design
- Static load: up to 2,800 kg
- Typical payload: 300 kg to 1,000 kg
- Rope distance (ASL): 400 mm to 1,100 mm, adjustable in 50 mm steps
- Traction sheave: 120 mm to 240 mm
- Deflection pulley: 160 mm to 240 mm
- Version as illustrated or motor turned through 180°
- Can be delivered assembled or unassembled

Scope of delivery

- Frame with fastening material
- Deflection pulley with fastening material
- Rope guard
- Insulating elements

Options

- Special adaptation of the frame
- Rope terminations

Information

ZAtop

ZAsyn

ZAdisc

VFD

System components motors

Control technology

System components control technology

Appendix

MK2800						
Motor type	Traction sheave D1	Deflection pulley		ASL	Max. static load	Article no.
		Diameter	Rim width max.			
	mm	mm	mm	mm	kg	
SM132.21/B	120-200	160	106	400-1100	2800	70028312 70028314
SM132.35/B		200	88			
SM160.30B/40B	120-240					
SM190.15/23	200					
	240					
SM200.15C/20C/30C	120-240					

Dimensions mm

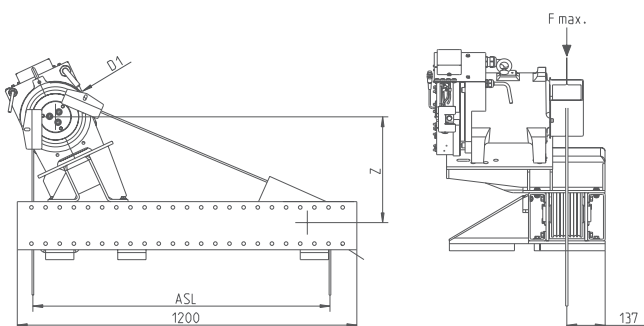

Motor type	Z
	mm
SM132.21/B	415
SM160.30B/40B	435
SM190	465
SM200.15C/20C/30C	465

ZAframe MN3300

Maschine frame for ZAtop SM200.15C - SM200.40D

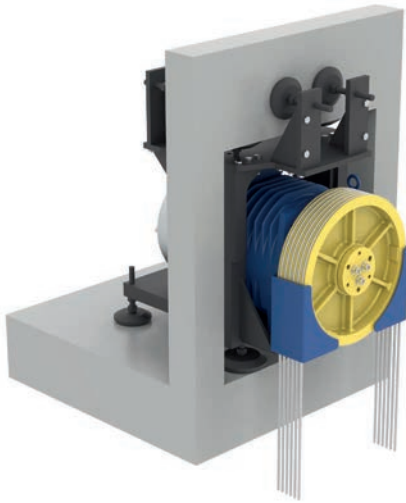

Description

- Frame for installation position traction sheave in the shaft
- Welded / screwed construction
- Static load: up to 3,300 kg
- Typical payload: 450 kg to 1,600 kg

Scope of delivery

- Frame with fastening material

Dimensions mm

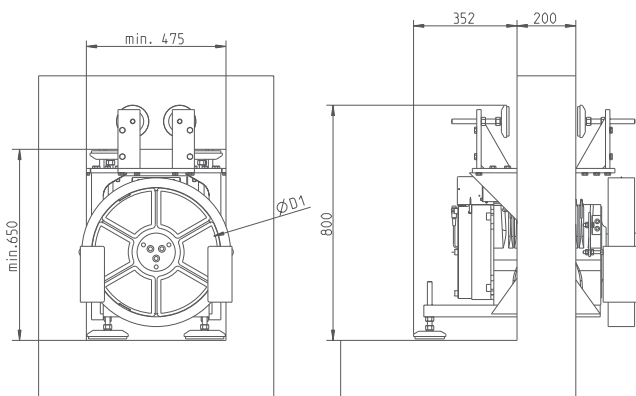

Motor type	Traction sheave D1 mm	Max. static load kg	Article no.
SM200.15C	320	3300	70028146
SM200.20C	320		
SM200.30C	320		
SM200.40D/45D	320		70028147
SM200.20C	400		70028146
SM200.30C	400		
SM200.40D/45D	400		
SM200.20C	450		
SM200.30C	450		
SM200.40D/45D	500		70028147

ZAframe MP350/MP500/MP3300

Mechanical adapter

Description

- Adapter for existing sub-structures
- For screwed/welded mounting

Scope of delivery

- Adapter plates or adapter rail
- Fastening material for motor

MP350 / MP500

Adapter plates for ZAtop SM160.30B - SM250.80D



MP3300

Adapter rail for ZAtop SM160.30B - SM200.40C longitudinal or transversal to traction sheave shaft

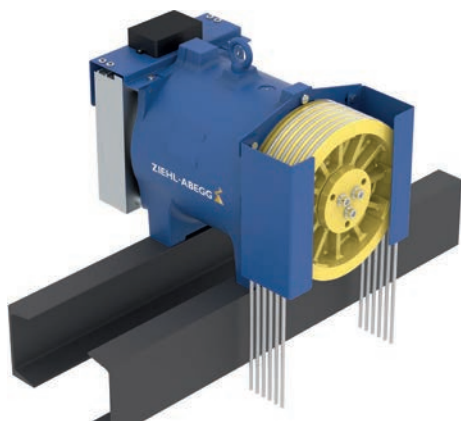

Motor type	Article no.	Dimensions (W x H x D) mm	Weight kg
SM160.30B/40B	70027343	350 x 40 x 300	48
SM190.15/23	70027344		
SM200.15C/20C/30C	70027344		
SM200.40D/45D	70027345		
SM225.60B	70027376	500 x 40 x 250	72
SM250.60B			
SM250.80D			

Motor type	Mounting	Article no.	Length mm	Weight kg
SM160.30B/40B	longitudinal	70028534	1000	19
	transversal	70027242		
SM190.15/23	longitudinal	70028535		
	transversal	70027242		
SM200.15C/20C/30C	longitudinal	70028535		
	transversal	70027242		
SM200.40D/45D	longitudinal	70028536		
	transversal	70027243		

Information

ZAtop

ZAsyn

ZAdisc

VFD

System components motors

Control technology

System components control technology

Appendix

Deflection pulleys



Scope of delivery

- Deflection pulley (plastic) with deep groove ball bearings including axle
- Two axle keep plates
- Mounting screws
- Washers
- Spacer sleeves

Options

- Two angle brackets

Deflection pulleys with axle and axle keep plates

Deflection pulley diameter	Rope diameter	Number of grooves	Groove spacing	Rim width	Axle diameter	Axle length	Bearing type	Weight without axle	Max. axle load
mm	mm		mm	mm	mm	mm		kg	kg
120	6 + 6.5	6	10	70	40	132	BS2 2208-2CS	1.9	2500
160	4	7	10	80	55	170	6211-2RS	4.5	1000
		12	10	126	55	190	6211-2RS	5.5	1650
	8.1	4	12	54	55	170	6211-2RS	4.0	2000
		6	12	84	55	170	6211-2RS	4.5	2000
		8	12	108	55	170	6311-2RS	5.0	3000
210	6 - 6.7	7	10	82	55	170	6211-2RS	5.6	2000
		10	10	112	55	190	6211-2RS	7.2	2500
240	6 - 6.7	7	10	82	55	170	6211-2RS	5.6	2000
		10	10	112	55	190	6211-2RS	7.2	2500
		12	10	134	55	190	6211-2RS	7.2	2500
320	6.5 - 6.7	14	10	156	55	230	6311 2RS	9.2	3000
	6.5 - 6.7	10	10	116	60	170	6212-2RS	8.4	3000
8		6	17	116	60	170	6212-2RS	8.4	3000
7		14	116	60	170	6212-2RS	8.4	3000	
10		17	182	60	250	6312-2ZR.L272	17.8	5000	
400	8	12	14	182	60	250	6312-2ZR.L272	17.8	5000
		6	17	116	60	170	6212-2RS	9.8	3000
		7	14	116	60	170	6212-2RS	9.8	3000
		10	17	182	60	250	6312-2ZR.L272	18.4	5000
	10	12	14	182	60	250	6312-2ZR.L272	18.4	5000
		5	17	116	60	170	6212-2RS	9.8	3000
		7	17	138	60	210	6312-2ZR.L272	14.2	5000
		10	17	182	60	250	6312-2ZR.L272	18.4	5000
520	10	17	182	60	250	BS2-2212-2CS	19	6000	
	12	6	20	145	60	210	6312-2ZR.L272	23.2	5000
	13	6	20	145	60	210	6312-2ZR.L272	23.2	5000

Special deflection pulleys on request



Forced ventilation ZAtop



Example of axial forced ventilation ZAtop SM250.60B



Example of forced cooling ZAtop SM200.30C

Description

For mounting on elevator machines of the ZAtop series

Information

ZAtop

ZAsyn

ZAdisc

VFD

System components motors

Control technology

System components control technology

Appendix

Forced ventilation for ZAtop			
Elevator machine	Mounting type	Article no.	Comment
SM180.45	On top	70029824	With and without hand release
SM200.15-30B/C	On top	70027042	With and without hand release
SM200.40C/D	On top	70027114	With and without hand release
SM200.45D	On top	70027114	With and without hand release
SM210.60	On top	70029725	With and without hand release
SM210.70	On top	70029727	With and without hand release
SM225.40B/45C	On top	70028013	With and without hand release
SM225.60B	Side B	70026808	Without hand release system Warner-brake
	On top	70026995	With hand release Warner-brake
	On top	70026995	With and without hand release Mayr-brake
SM250.45B	Side B	70029708	With and without hand release
	On top	70026995	With and without hand release
SM250.60B	Side B	70028260	Without hand release system
	Side B	70028262	With hand release
	On top	70027021	With and without hand release
SM250.80D	On top	70027846	With and without hand release
SM250.100C	On top	70026764 + 02010643	With and without hand release Terminal box right
	On top	70026847 + 02010643	With and without hand release Terminal box left

Article no. valid for machine built from 2014 onwards.

Oil heating motors

The solution for oil tanks in elevator and industrial hydraulics



Description

- Short-circuit proof motor for heating up hydraulic oils
- Gently heat-up oils and prevent movement and cracking through rotation
- Nearly the entire electrically absorbed energy is converted into heat
- For hydraulic oil types HL and HLP with viscosity class 22-46

FZ023-4EA.OC.V7

- Bracket with magnetic clamps
- Temperature controller
 - Closing temperature $15^{\circ}\text{C} \pm 3^{\circ}\text{C}$
 - Opening temperature $23^{\circ}\text{C} \pm 3^{\circ}\text{C}$
- Terminal box

FZ025-4DA.4C.A6

- Terminal box

Options FZ025-4DA.4C.A6

- Temperature controller (article no. 02001138)
 - Closing temperature $15^{\circ}\text{C} \pm 3^{\circ}\text{C}$
 - Opening temperature $23^{\circ}\text{C} \pm 3^{\circ}\text{C}$

Oil heating motors			
Type		FZ023-4EA.OC.V7	FZ025-4DA.4C.A6
Article no.		880004751	104873
Thermal output at 100 rpm	kW	0.5	1.4
Current consumption at 100 rpm	A	2.2	2.8
Connection voltage		1~ 230 V / 50 Hz	3~ 400 V AC / 50 Hz
Insulation class		F	F
Weight	kg	4.0	9.0
Blade diameter	mm	230	250

Dimensions mm

FZ023-4EA.OC.V7

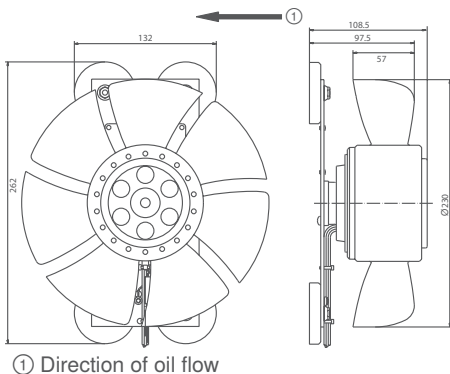

FZ025-4DA.4C.A6

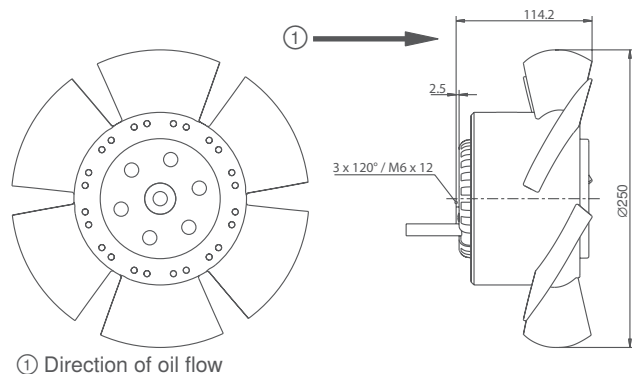

Tool set

Tool set for changing the brake on ZAtop SM160 - SM250C



Description

Tool set for changing the brake on elevator machines of the ZAtop series. The assembly bolts are graded in three sizes for the different brake types. Details for changing the brake are described in the operating instructions of the respective motor.

Article no. 70027450

Scope of delivery

The tool set contains:

Quantity	Article no.	Designation
1	01003811	Mounting Tool
1	01005372	Mounting shaft complete
1	00003390	Cylinder screw M10 x 25 - 8.8
2	01007976	Assembly bolts 12 x 220 mm
2	02014692	Assembly bolts 16.1 x 258 mm
4	02014693	Assembly bolts 21.1 x 300 mm
1	02020060	Plastic suitcase

Information

ZAtop

ZAsyn

ZAdisc

VFD

System compo-
nents motorsControl
technologySystem com-
ponents control
technology

Appendix

ZAlift Calculation software

Calculation software for elevator machines from ZIEHL-ABEGG



ZAlift - the tool for selection of your elevator components. Based on the entered plant data, ZAlift calculates the matching package of machine and frequency inverter. ZAlift supports with helpful information for installation, operation and final inspection of the elevator.

The functions

- Selection of the drive package based on the entered plant data
 - Gearless elevator machine ZATop, ZASyn and ZAdisc
 - Frequency inverter ZADyn
 - Power recuperation unit ZAreC4C
- Helpful informations for the final inspection
 - Traction conditions according to EN 81
 - Stopping distance according to EN 81 (unintended car movement)
 - Energy efficiency class of the elevator according to VDI 4707
- Helpful informations for the installation
 - Calculation of the power and current consumption of the elevator machine
- Extensive database of available suspension means
- Backup of the calculation (incl. data)

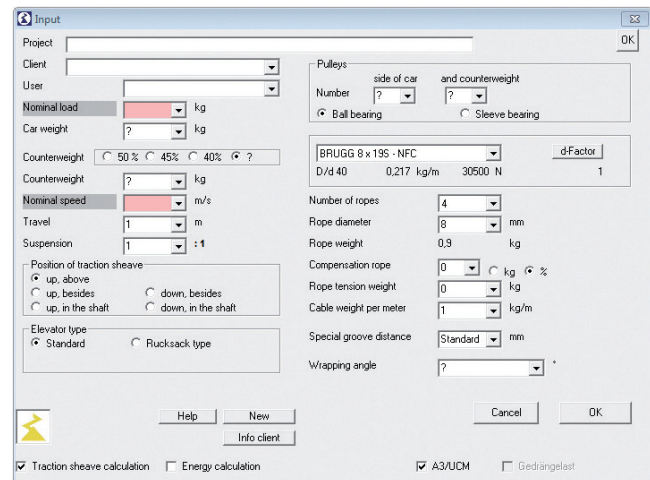

ZAlift is available as a free of charge download on the ZIEHL-ABEGG homepage.



- Information
- ZAtop
- ZAsyn
- ZAdisc
- VFD
- System components motors**
- Control technology
- System components control technology
- Appendix





Control technology

Product overview

Information	Page 74
ZAdyn4C	Page 78
ZAdynpro	Page 80
ZAdyn4B	Page 82
ZAdyn4CA HY	Page 84
EVAC 3C	Page 86
ZArec4C	Page 88

Information

ZAtop

ZAsyn

ZAdisc

VFD

System components
motorsControl
technologySystem components
control
technology

Appendix

Control technology

General information



Operators, residents and passengers have high demands when it comes to a cutting-edge lift system. In addition to travelling comfort, the noise emissions play an especially significant role in the evaluation of lifts. The contactorless frequency inverters from the ZAdyn4C and ZAdynpro series enable very low-noise operation of the lift drive. In this way, they make a major contribution to the realisation of a modern lift.

STO (Safe Torque Off) - contactor-less operation according to EN 81-20

The contactor-less operation of the elevator machine according to operating mode STO (Safe Torque Off according to IEC 61800-5-2 (SIL 3)) or EN ISO 13849 Category 3, Performance Level e meets the requirements of EN 81-20 to the separation of the power supply of the drive.

Electronic short-circuit

The short-circuiting of the motor windings of synchronous motors avoids in many cases uncontrolled acceleration of the drive and therefore ensures controllable evacuation of persons by manual opening of the motor brakes. The ZAdyn4C also has this function which was so well appreciated in its predecessors. It was implemented with consistent pursuance of the principle of the contactor-less frequency inverter and an electronic variant was developed. This is also active when no operating voltage exists!

ZAsbc4 - 100 % noiseless

The contactor-less operation of the elevator machine already makes a major contribution towards a low-noise elevator system. The ZAsbc4 increases this to 100%! Electronic switching of the brakes enables completely contactor-less operation of the elevator machine. This ensures minimum noise emissions and maximum comfort in the building.

Contactor-less operation - your benefit

- No switching noises
- Lower costs
- Lower power consumption
- Lower wiring costs
- No wearing components
- Reduced space requirements for the controller
- Safe operation





Specialists for elevator technology

Units for the ZAdyn series are frequency inverters solely developed for elevator technology. The various housing designs and the continuously compact construction makes them perfectly suitable for both switch cabinet mounting as well as for wall installation in the machine room or elevator shaft.

Both in rope elevators with synchronous or asynchronous motors as well as in hydraulic elevators, type ZAdyn frequency inverter provide the greatest travelling comfort and the most precise stopping accuracy.

The software, specifically matched to elevator technology, facilitates intuitive operation and fast commissioning. The high variety of various interfaces facilitate fast connection to the elevator controller.

Made by ZIEHL-ABEGG

A high degree of vertical integration means great flexibility. And an ultra-modern machine fleet is available to ensure that. From component placing in the boards up to the final test and inspection of the frequency inverter and their accessories, the entire ZAdyn series is produced in our headquarters in Künzelsau. That enables us to meet our partners' demands for flexibility and speed.



EMC-conform without any great effort

All standards which are obligatory for elevator systems are complied with through the line reactor and the radio interference filter integrated in the ZAdyn4C.

EN 12015: Electromagnetic compatibility - Product family standard for lifts, escalators and moving walks - Emission

EN 12016: Electromagnetic compatibility - Product family standard for lifts, escalators and moving walks - Immunity

With the integration of the EMC components, the ZAdyn4 provides the user with even more advantages:

- No mounting and wiring effort
- Use of components specifically matched to the ZAdyn4
- No risk regarding the compliance with EMC standards
- No additional space requirement

Information

ZAtop

ZAsyn

ZAdisc

VFD

System components motors

Control technology

System components control technology

Appendix

Control technology

General information



Data backup and recording measuring curves

- fast and simple!

Alle Devices of the ZAdyn, ZAreC and EVAC 3 series as well as the ZApad operating terminal are equipped with an interface for a conventional MMC / SD card. The use of an MMC / SD card provides many functions which simplify the work.

Data backup:

- Data backup for professional documentation without special software
- Copying of parameters for identical elevator systems

Recording measuring curves:

- 4 analogue and 1 digital measuring channel – freely configurable
- Saving of normal and faulty travels
- Extended error analysis in servicing by measured value storage
- Analysis of sporadic errors
- Long-term documentation of travel processes



Better energy efficiency of your system!

In typical elevator systems, the unused energy generated during travel is converted by a brake resistor into waste heat. From an environmental perspective, this approach is put into question by increasing resource scarcity, rising energy costs and the resulting increasing demands for energy efficiency and sustainability, which require ways of using the unexploited energy potential. These requirements are met by using the ZAreC power recuperation unit. The generated energy is preprocessed and fed back into the power supply. ZAreC has been developed especially for brief, highly dynamic recuperation operation, such as that which occurs in elevator systems.



More competence.

More experience.

More commitment.

In addition to excellent, easy to use products, personal customer support and fast, on-time delivery, customer-orientated service is also one of our special strengths. Competent support by specialised, experienced service staff are prerequisite for saving time and costs on site. With our comprehensive service package we therefore make an essential contribution to fast start-up of your elevator system.

- Technical design of drive systems
- Application-engineering consulting when selecting frequency inverters, elevator machines, evacuation units, recuperation units and their system components
- Preset of all parameters of the ZAdyn before delivery when ordering drive packages (machine with frequency inverter) from ZIEHL-ABEGG
- Service hotline for start-up or technical questions
- Technical service and training on-site



- Information
- ZAtop
- ZAsyn
- ZAdisc
- VFD
- System components motors
- Control technology**
- System components control technology
- Appendix



ZAdyn Frequency inverter for elevator machines

4C - The solution for wall installation



Operating terminal ZApad	Page 92
Brake resistors BR	Page 93
Brake control ZAsbc4	Page 94
Control and connection cables	Page 101
Encoder cables	Page 112
Evacuation unit EVAC 3C	Page 86
Power recuperation unit ZArec4C	Page 88

Contactor-less operation:

- STO (Safe Torque Off) according to IEC 61800-5-2 (SIL 3) or EN ISO 13849 category 3, Performance Level e with protection class IP20.
- Requirements of EN 81-20 to the disconnection of the power supply of the drive are met!

Technical data

Type	Article no.	Phases	Nominal voltage VAC	Mains frequency Hz	Motor power typ. W	Nominal current A	Current max. A	Duty cycle %	Weight kg
ZAdyn4CA 011	352194	3~	400	50/60	4.6	11	20	60	11.80
ZAdyn4CS 011	352201				12.00				
ZAdyn4CA 013	352195				5.5	13	24		12.60
ZAdyn4CS 013	352202				12.80				
ZAdyn4CA 017	352196				7.5	17	31		13.00
ZAdyn4CS 017	352203				13.20				
ZAdyn4CA 023	352197				11	23	42		14.10
ZAdyn4CS 023	352204				14.30				
ZAdyn4CA 032	352198				14	32	58		16.40
ZAdyn4CS 032	352205				16.60				
ZAdyn4CA 040	352206				19	40	72		32.40
ZAdyn4CS 040	352216				32.60				
ZAdyn4CA 050	352207				24	50	90		33.30
ZAdyn4CS 050	352217				33.50				
ZAdyn4CA 062	352208				30	62	112		36.20
ZAdyn4CS 062	352218				36.40				
ZAdyn4CA 074	352209	37	74	134	36.40				
ZAdyn4CS 074	352219	36.60							

Description

- Wall mounting in the machine room or elevator shaft
- Mounting in the control cabinet
- Line reactor, radio interference filter integrated
- Space-saving installation by compact design
- Operation of synchronous motors (ZAdyn4CS) and asynchronous motors (ZAdyn4CA)
- Open-Loop-Operation of asynchronous motors
- Standby function
- 4-line display with plain text display
- Minimal noise generation and low energy consumption through controlled ventilation
- Automatic operating-curves default
- Switching frequency: 4...16 kHz (automatic adaptation)
- Applied EMC standards: EN 12015 and EN 12016
- Protection class: IP20

Interfaces

Controller

- Programmable inputs and outputs
 - 5 x relay output (potential-free)
 - 12 x digital inputs (24 VDC)
- DCP
- CANopen-Lift
- All interfaces galvanic isolated

Encoder

- Incremental
 - HTL / TTL / Sine
- Absolute
 - EnDat / SSI / SinCos / Hiperface / BiSS-C
- Simulation for controller

Monitorings

- Temperature monitoring brake resistor
- Temperature monitoring motor (in accordance with EN 61800-5-1:2008-04)
- Motor contactor monitoring (with optional use of motor contactors)
- Brake release monitoring in accordance with EN 81-20

Features

- MMC / SD card interface for data backup and exchange
- USB interface for ZAMon software (via ZApad)

Options

- External ZApad operating terminal; 4-line display with plain text display
- Electronic brake control ZAsbc4
- ZAMon software

Evacuation mode

Supply during power failure through:

- EVAC 3C evacuation unit
- Uninterruptible power supply (UPS)

Electromagnetic compatibility

Compliance with EN 12015 and EN 12016 through integration of line reactor and radio interference filter in the ZAdyn4C.

Frequency inverter	Brake resistor	Article no.
ZAdyn4C 011	BR11-A	357171
	BR14-A	357195
	BR17	357216
ZAdyn4C 013	BR14-A	357195
	BR17	357216
ZAdyn4C 017	BR17	357216
ZAdyn4C 023	BR25	357217
ZAdyn4C 032	BR25	357217
	BR50	357218
ZAdyn4C 040	BR50	357218
ZAdyn4C 050	BR50	357218
ZAdyn4C 062	BR50	357218
ZAdyn4C 074	BR50	357218
	BR100-A	357214

Dimensions mm

ZAdyn4C 011-032

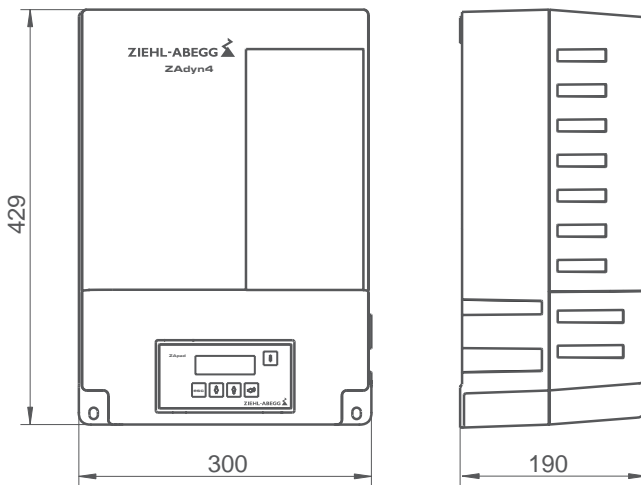

ZAdyn4C 040-074

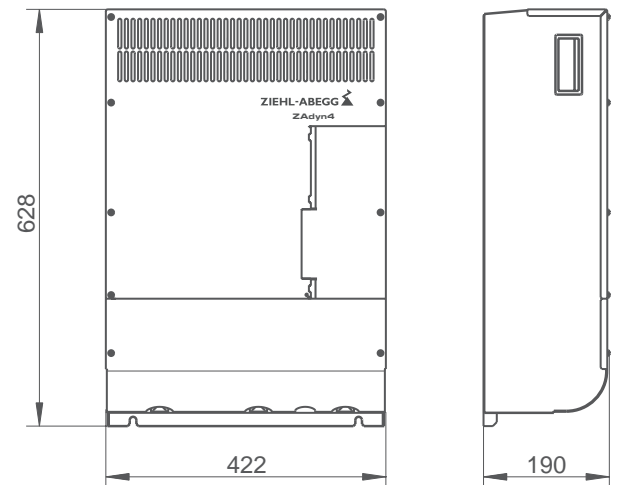

ZAdyn Frequency inverter for elevator machines

Pro - the solution for control cabinet mounting



Description

- Mounting in the control cabinet
- Radio interference filter integrated
- Space-saving installation by compact design
- Operation of synchronous motors and asynchronous motors
- Open-Loop-Operation of asynchronous motors
- Standby function
- 4-line display with plain text display
- Minimal noise generation and low energy consumption through controlled ventilation
- Automatic operating-curves default
- Switching frequency: 4...16 kHz (automatic adaptation)
- Applied EMC standards: EN 12015 und EN 12016
- Protection class: IP20

Interfaces

Controller

- Inputs (24 VDC)
 - 8 x digital inputs, freely programmable
 - 3 x digital inputs monitoring of motor brakes
 - 1 x digital input monitoring of braking resistor
- Outputs
 - 3 x relay output (250 VAC / 2 A)
 - 2 x mini relay output (24 VDC / 1 A)
- CANopen-Lift
- All interfaces galvanic isolated

Encoder

- Incremental
 - TTL / Sine
- Absolute
 - EnDat / SSI / SinCos / Hiperface / BiSS-C
- Simulation for controller

Monitorings

- Temperature monitoring brake resistor
- Brake release monitoring in accordance with EN 81-20

Operating terminal ZApadpro	Page 92
Brake resistors BR	Page 93
Brake control ZAsbc4	Page 94
Control and connection cables	Page 105
Encoder cables	Page 112
Evacuation unit EVAC 3C	Page 86
Power recuperation unit ZArec4C	Page 88

Contactless operation:

- STO (Safe Torque Off) according to IEC 61800-5-2 (SIL 3) or EN ISO 13849 category 3, Performance Level e with protection class IP20.
- Requirements of EN 81-20 to the disconnection of the power supply of the drive are met!

Technical data

Type	Article no.	Phases	Nominal voltage VAC	Mains frequency Hz	Motor power typ. W	Nominal current A	Current max. A	Duty cycle %	Weight kg
ZAdynpro 011	352250	3~	400	50/60	4.6	11	20	40	4.50
ZAdynpro 013	352251				5.5	13	24		4.50
ZAdynpro 017	352252				7.5	17	31		4.60
ZAdynpro 023	352253				11	23	42		6.00
ZAdynpro 032	352254				14	32	58		6.10



Features

- MMC / SD card interface for data backup and exchange
- USB interface for ZAMon software (via ZAPadpro)

Options

- External ZAPadpro operating terminal; 4-line display with plain text display
- Electronic brake control ZAsbc4
- ZAMon software

Evacuation mode

Supply during power failure through:

- EVAC 3C evacuation unit
- Uninterruptible power supply (UPS)

Electromagnetic compatibility

Compliance with EN 12015 and EN 12016 through integration of a line reactor Typ ND... in the mains supply.

Frequency inverter	Brake resistor	Article no.
ZAdynpro 011	BR11-A	357171
	BR14-A	357195
	BR17	357216
ZAdynpro 013	BR14-A	357195
	BR17	357216
ZAdynpro 017	BR17	357216
ZAdynpro 023	BR25	357217
ZAdynpro 032	BR25	357217
	BR50	357218

Dimensions mm

ZAdynpro 011-017

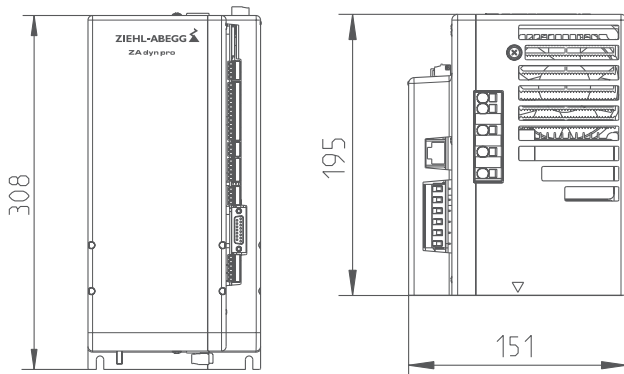

ZAdynpro 023-032

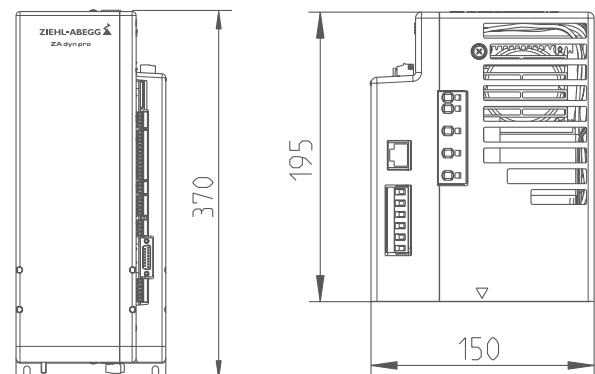

- Information
- ZAtop
- ZAsyn
- ZAdisc
- VFD
- System components motors
- Control technology
- System components control technology
- Appendix

ZAdyn Frequency inverter for elevator machines

4B -The solution for high performances

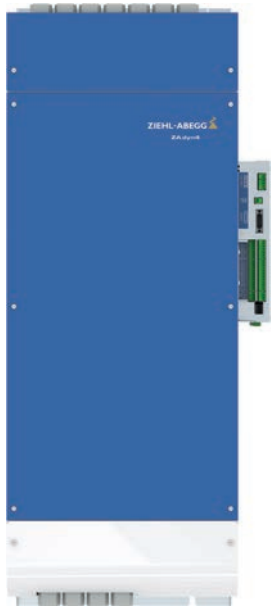

Description

- Mounting in the control cabinet
- Space-saving installation through compact design
- Operation of synchronous motors (ZAdyn4BS) and asynchronous motors (ZAdyn4BA)
- Open-Loop-Operation of asynchronous motors
- Standby function
- 4-line display with plain text display
- Minimal noise development and low energy consumption by controlled ventilation
- Automatic operating-curves default
- Switching frequency: 4...16 kHz (automatic adaptation)
- Applied standards: EN 12015 and EN 12016
- Protection class: IP10

Interfaces

Control

- Programmable inputs and outputs
 - 5 x relay outputs (potential-free)
 - 5 x relay output (potential-free)
 - 12 x digital inputs (24 VDC)
- DCP
- CANopen-Lift
- All interfaces electrically isolated

Encoder

- Incremental
 - HTL / TTL / sine
- Absolute
 - EnDat / SSI / SinCos / Hiperface / BiSS-C
- Encoder simulation for controller

Monitoring

- Temperature monitoring brake resistor
- Temperature monitoring motor (according to IEC 61800-5-1:2008-04)
- Motor contactor monitoring
- Brake release monitoring according to EN 81-20

Operating terminal ZApad	Page 92
Brake resistors BR	Page 93
Brake control ZAsbc4	Page 94
Control and connection cables	Page 101
Encoder cables	Page 112
Power recuperation unit ZArec4C	Page 88

Technical data

Type	Article no.	Phases	Nominal voltage VAC	Mains frequency Hz	Motor power typ. W	Nominal current A	Current max. A	Duty cycle %	Weight kg	
ZAdyn4BA 110	352210	3~	400	50/60	55	110	198	60	57.00	
ZAdyn4BS 110	352212									
ZAdyn4BA 180	352211					180				63.00
ZAdyn4BS 180	352213									



Features

- MMC / SD card interface for data backup and exchange
- USB interface for ZAMon software (by ZApad)

Options

- External operating terminal ZApad; 4-line display with plain text display
- Electronic brake control ZAsbc4
- ZAMon software

Electromagnetic compatibility

Compliance with EN 12015 by use of:

- Line reactor ND
- Radio interference filter FEF

Frequency inverter	Brake resistor	Article no.
4B 110	BR100-B	357215
4B 180	BR100-B	357215

Dimensions mm

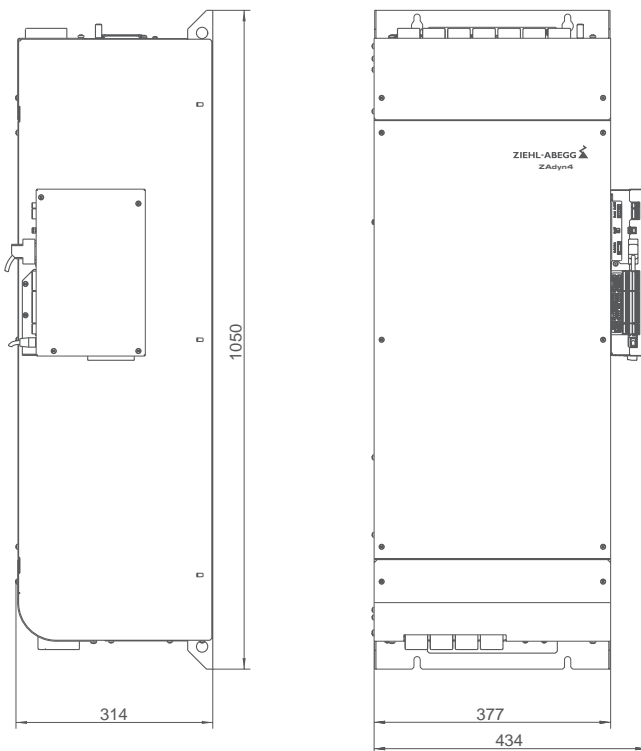

- Information
- ZAtop
- ZAsyn
- ZAdisc
- VFD
- System components motors
- Control technology
- System components control technology
- Appendix

ZAdyn Frequency inverter for elevator machines

4CA HY - the solution for modernization of hydraulic elevators

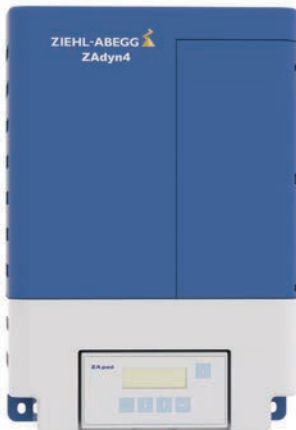

Description

- Changeover to frequency-regulated operation
- No need to intervene in the hydraulic system
 - The asynchronous motor of the hydraulic pump is operated using a specially developed pseudo closed-loop procedure with DCP04

Compatible valve blocks

- Bucher Hydraulics GmbH: lift control valve LRV-1
- Blain Hydraulics GmbH: control valve type EV 100
- GMV Oildynamic: control block 3010
- ALGI Alfred Giehl GmbH & Co. KG: control block type AZSTB
- Further types on request

Interfaces

- Control system
- Programmable inputs and outputs
 - 5 x relay outputs (floating)
 - 5 x relay output (floating)
 - 12 x digital inputs (24 VDC)
 - DCP
 - CANopen-Lift
 - All interfaces are electrically isolated

Operating terminal ZApad	Page 92
Control and connection cables	Page 101

Contactor-less operation:

- STO (Safe Torque Off) according to IEC 61800-5-2 (SIL 3) or EN ISO 13849 category 3, Performance Level e with protection class IP20.
- Requirements of EN 81-20 to the disconnection of the power supply of the drive are met!

Technical data

Type	Article no.	Phases	Nominal voltage VAC	Mains frequency Hz	Motor power typ. W	Nominal current A	Current max. A	Duty cycle %	Weight kg
ZAdyn4CA 018 HY	352240	3~	400	50/60	7.5	18	23	60	12.60
ZAdyn4CA 025 HY	352241				11	25	31		13.00
ZAdyn4CA 032 HY	352242				14	32	40		14.10
ZAdyn4CA 040 HY	352243				19	40	50		16.40
ZAdyn4CA 050 HY	352244				22	50	63		32.40
ZAdyn4CA 063 HY	352245				30	63	79		33.30
ZAdyn4CA 080 HY	352246				37	80	100		36.20
ZAdyn4CA 105 HY	352247				50	105	131		36.40



Features

- MMC / SD card interface for data backup and exchange
- USB interface for ZAmom software (via ZApad)

Options

- External ZApad operating terminal; 4-line display with plain text display

Evacuation mode

Supply during power failure through:

- EVAC 3C evacuation unit
- Uninterruptible power supply (UPS)

Electromagnetic compatibility

Compliance with EN 12015 and EN 12016 through integration of line reactor and radio interference filter in the ZAdyn4C.

Dimensions mm

ZAdyn4C 018-040 HY

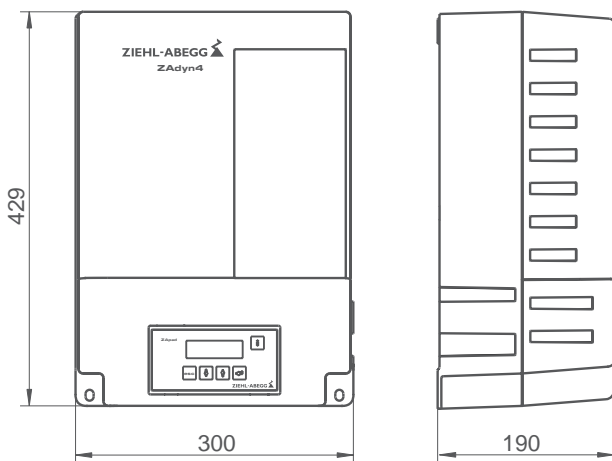

ZAdyn4C 050-105 HY

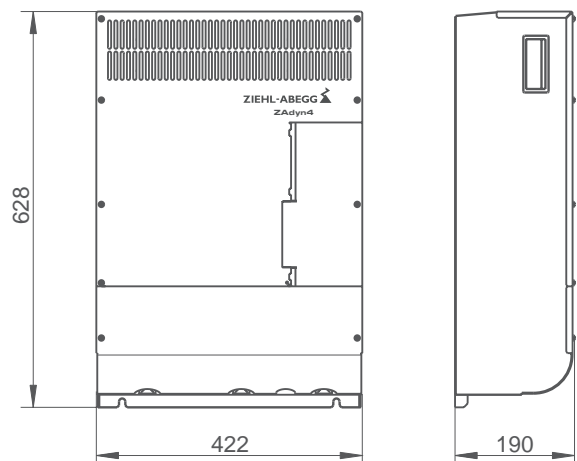

- Information
- ZAtop
- ZAsyn
- ZAdisc
- VFD
- System components motors
- Control technology
- System components control technology
- Appendix

Evacuation unit

EVAC 3C - The solution for wall installation



Monitoring of the power supply and activation of the evacuation travel

The evacuation unit EVAC 3C monitors the mains power supply of the lift system. If one or more supply phases fail, the frequency inverter is disconnected from the supply network. The lift control system and frequency inverter are simultaneously informed of the power failure. The battery power supply is then connected with a time delay. The frequency inverter switches to emergency mode (reduced speed) and an evacuation can be started via the lift control system regardless of the current load ratios.

The alternative to a complex and drawn-out process of having trapped individuals freed by third-party personnel.

Operating terminal ZETAPAD	Page 92
Frequency inverter ZAdyn4C	Page 78
Frequency inverter ZAdynpro	Page 80
EVAC Battery set and wiring harness	Page 107

Description

- Wall installation in machine room or elevator shaft
- For synchronous and asynchronous motors
- For frequency inverters type ZETADYN 3 and ZAdyn
- 60 min availability (with restricted number of trips)
- Integrated mains monitoring
- Integrated charger for controlled charging of lead-gel rechargeable battery
- Operation and configuration via the ZETAPAD operating terminal
- Monitoring of the battery temperature
- Function test via digital input
- LED display for operation / fault
- 4 x relay outputs
- 4 x digital inputs (24 VDC)
- External main switch; that permits installation in the elevator shaft
- Prefabricated cables for fast installation
- Power contactors for switching from normal to battery mode
- Integrated inverted rectifier 230 VAC / 500 W to supply:
 - Elevator controller
 - Cabin light
 - Door drive
 - Motor brake
- SD card slot for data backup

Technical data

Type	Article no.	Phases	Nominal voltage VAC	Mains frequency Hz	Nominal current A	Battery voltage	Battery type	Time limit evac. s	Weight kg
EVAC 3C032	357231	3~	400	50/60	32	120...180	Lead-gel batteries	20	33.20
EVAC 3C050	357232				50				34.70
EVAC 3C074	357233				74				38.40



Features

- External operating terminal ZETAPAD
- MMC/SD card interface for data backup and exchange

Options

- Wiring harness LS-EVAC3C-03-HX-...-ZA3/4
- Wiring harness LS-EVAC3C-...-HX-ST

Additionally required components

- Battery set corresponding to the required output
- 4-pole main switch

Simplified diagram

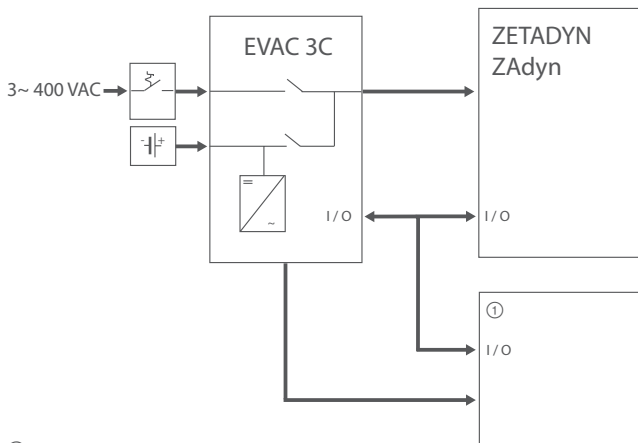

① Elevator control

Dimensions mm

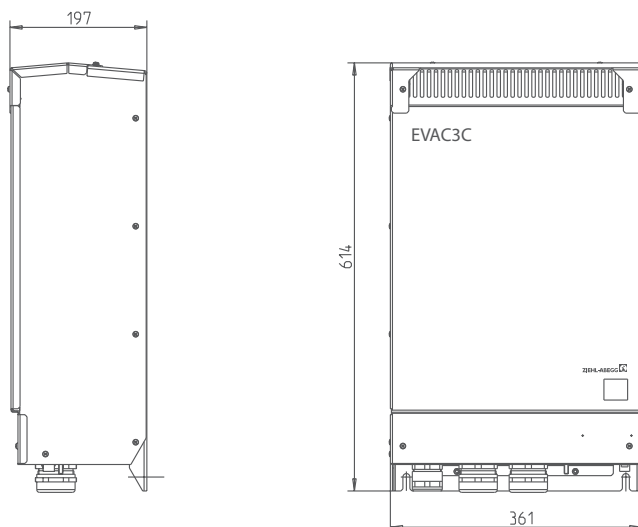

Power recuperation units

ZArec4C - The solution for improving energy efficiency and sustainability



With the ZArec power recuperation unit the demands for energy efficiency and sustainability of elevator systems are met. The generated energy is preprocessed and fed back into the power supply. ZArec has been developed especially for brief, highly dynamic recuperation operation, such as that occurs in elevator systems.

Description

- Extremely flat design
- Perfect for the elevator shaft
 - ZArec4C 013: Mounting above the landing door
 - ZArec4C 026 / 039: Mounting between the guiding rails
- Wall mounting in the machine room or elevator shaft
- Can be used for ZETADYN 3, ZAdyn4C and ZAdynpro type frequency inverters
- Integrated standby function for saving energy
- Prefabricated cables for fast assembly
- Applied standards: EN 12015 and EN 12016
- Protection class: IP20
- Max. on-time: 20%

Interfaces

- 2x relay outputs
- 2x digital inputs

Regeneration "Clean energy"

- Sinusoidal regenerative power through integrated EMC components
- Harmonic waves I1/I5: < 5 %
- Distortion factor THD: < 5 %
- Requirements of EN 12015 for the electromagnetic compatibility are met
- No interference with network infrastructure
- No interference with the function of other devices connected to the mains power supply, e.g. computers, medical devices or radios

Operating terminal ZApad	Page 92
Frequency inverter ZAdyn4C	Page 78
Frequency inverter ZAdynpro	Page 80
Wiring harnesses	Page 106
Brake resistors BR	Page 93

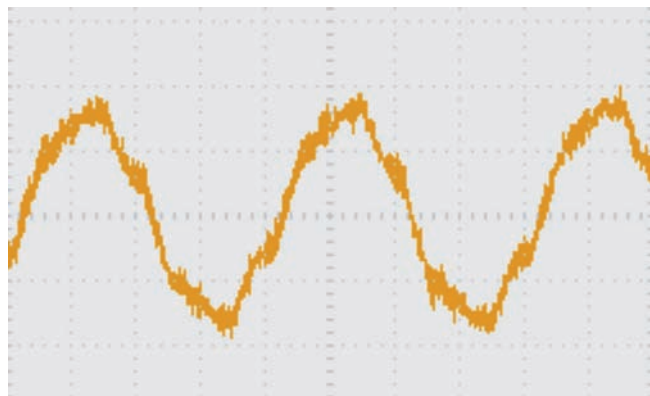

Sinusoidal power feed-in

Technical data

Type	Article no.	Phases	Nominal voltage VAC	Mains frequency Hz	Recuperation power kW	Max. recuperation current A	Power loss standby W	Weight kg
ZArec4C 013	357269	3~	400	50	5	7	< 10	42.50
ZArec4C 026	357294				10	14.4		61.00
ZArec4C 039	357295				15	21.7		78.00



No additional brake resistor for evaluations

During evacuation travel, the brake resistor belonging to the ZArec converts the created energy into heat. Additional costs for an additional brake resistor are saved.

Brake resistor allocation

Type	Brake resistor	Article no.
ZArec4C 013	integrated	-
ZArec4C 026	BR25-3	357217
ZArec4C 039	BR50-3	357218

Dimensions mm

ZArec4C 013

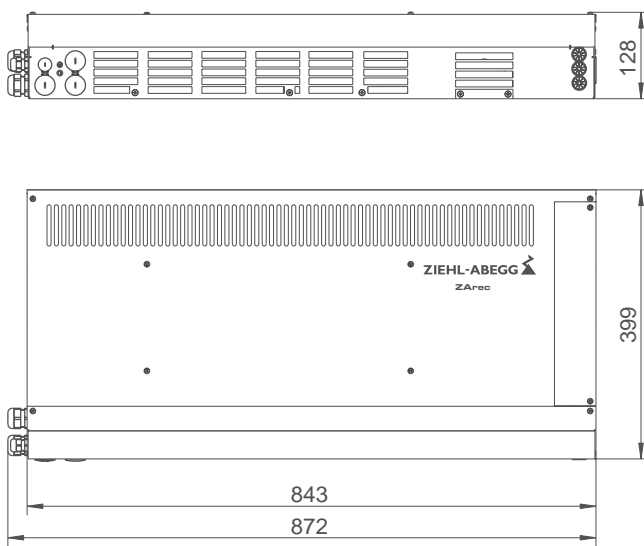

ZArec4C 026-039

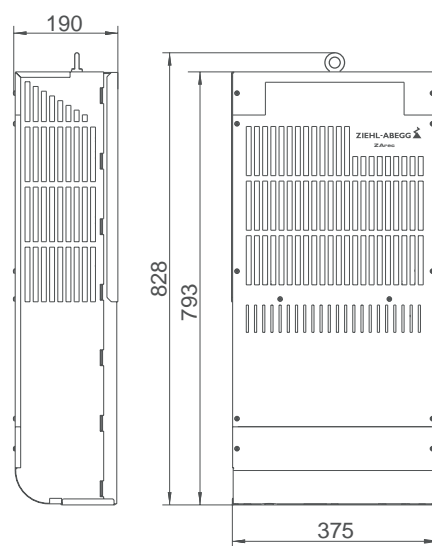



ZApad

ZAdyn
→Startup
Statistik
Memory Card

esc



ZIEHL

System components control technology

Product overview

ZApad / BR100-BOX	Page 92
Brake resistor BR	Page 93
Electronic brake control ZAsbc4	Page 94
Line reactor	Page 96
Radio interference filter	Page 97
Retrofit kits	Page 98
Control and connection cables ZAdyn4	Page 101
Connection cables ZAdynpro	Page 105
Control and connection cables ZAsbc4	Page 105
Connection cables ZApad	Page 106
EVAC Battery set and wiring harness	Page 107
Motor cables	Page 108
Encoder cables	Page 112
Encoder incremental	Page 115
Absolute encoder / adapter cables	Page 117
Software ZAMon	Page 118

Information

ZAtop

ZAsyn

ZAdisc

VFD

System components motors

Control technology

System components control technology

Appendix



ZApad

Operating terminal ZApad



Description

- External operating terminal for
 - ZAdyn4
 - ZAdynpro
 - ZAreC4
 - EVAC 3
 - ZETADYN 3
- 4-line display with plain text display

ZApad for ZAdyn4 and ZAreC4 (white)
Article No. 357256



ZApadpro for ZAdynpro (white)
Article No. 357300



ZETAPAD for ZETADYN 3 and EVAC 3 (anthracite)
Article No. 357190V2

BR100-BOX



For connection of two or three BR100-3B type brake resistors to ZAdyn4B 110/180.

Description

- Connection box with integrated terminals
- For parallel connection of up to three BR100-3B type brake resistors

BR100-BOX
Article no. 357261



Brake resistor BR



BR17 - BR100



BR09 - BR14

For converting the energy generated during regenerative travel into heat.

Description

- Prepared for wall installation
- Compact design
- Integrated temperature monitoring (only BR...-3)
- Integrated connection cable (only BR...-A)

Technical data

Type	Article no.	Max. peak current A	Continuous braking power kW	Temperature monitor trigger °C	Cable length m	Protection class	Weight kg
BR09-1	357120	9.0	0.29	-	1.0*	IP50	0.8
BR11-A	357171	11.0	0.45	-	1.0*	IP50	1.8
BR14-A	357195	14.0	0.85	-	1.0*	IP50	2.9
BR17-3	357216	17.0	1.75	137 ± 4 K	5.0**	IP20	2.6
BR25-3	357217	25.0	1.75	137 ± 4 K	5.0**	IP20	2.6
BR50-3	357218	50.0	3.3	137 ± 4 K	5.0**	IP20	4.8
BR100-3A	357214	100.0	6.5	125 ± 4 K	5.0**	IP20	8.5
BR100-3B	357215	100.0	6.5	125 ± 4 K	5.0**	IP20	8.5

* Connection cable integrated

** Connection cable separate

Dimensions mm

BR09 - BR14

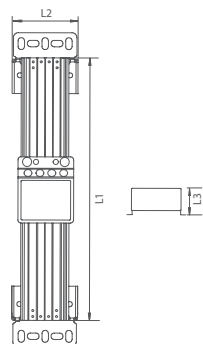

BR17 - BR100

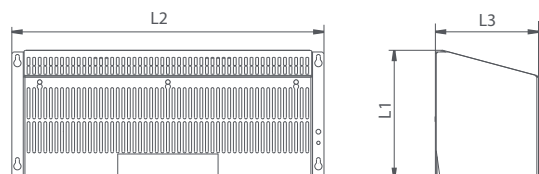

Type	L1	L2	L3
BR09-1	317	67	75
BR011-A	225	124	120
BR014-A	426	124	120

BR017-3	230	300	185
BR025-3	230	300	185
BR050-3	230	560	185
BR100-3A	414	560	185
BR100-3B	414	560	185

Electronic brake control

ZAsbc4



ZAsbc4C

Following conditions are necessary for comfortable travel behaviour of the elevator:

- Correctly timed switching of the brake
- Noiseless activation of the brake
- Low-noise switching of the brake

The electronic brake control ZAsbc4 meets these requirements.

The ZAsbc4 is available for mounting on to the ZAdyn4C frequency inverter and for installation in the switch cabinet.

Description

- Noiseless activation of the mechanical brake
- Correctly timed switching of the mechanical brake
- For brakes of synchronous and asynchronous motors
- Low-noise switching of the mechanical brake
- Minimum cable lengths for elevators without machine room
- Low space requirement for the controller



ZAsbc4B

Electronic brake control

- For brakes with and without overexcitation
- Operating voltage brake: 207 VDC / 103 VDC
- Evaluation of safety circuit and enabling of contactor-less operation
- Retrofittable
- Prefabricated cables for connection to elevator controller

- Control inputs:
 - Activation of brake
 - Evaluation of safety circuit
 - Push-buttons emergency operation and brake test

- Control outputs:
 - Activation of contactor-less operation ZAdyn
 - Status monitoring
 - Fault

Safety component according to the Lift Directive 2014/33/EU. The requirements relating to the disconnection of the energy supply to the brakes as stated in EN 81-20 are met!

Technical data

ZAsbc4C

- For mounting on ZAdyn4C
- Prefabricated cables for connection to ZAdyn4C

Type	Article no.	Voltage safety circuit	Voltage supply brake U~	Motor brake output voltage	Output current
		VAC	VAC	VDC	A
ZAsbc4C 110	357292	110	230	0.9 x U~	2 x 1.0
ZAsbc4C 230	357293	230		0.45 x U~	

ZAsbc4B

- For control cabinet installation

Type	Article no.	Voltage safety circuit	Voltage supply brake U~	Motor brake output voltage	Output current
		VAC	VAC	VDC	A
ZAsbc4B 110	357290	110	230	0.9 x U~	2 x 1.0
ZAsbc4B 230	357291	230		0.45 x U~	

Information

ZAtop

ZAsyn

ZAdisc

VFD

System components
motorsControl
technologySystem components control
technology

Appendix

Line reactor ND



Description

- For ZAdynpro and ZAdyn4B
- For compliance with the limits required by EN 12015 (interference emission)
- Reduction of the harmonics
- Damping of commutation notches and mains feedback

Technical data

Type	Article no.	Nominal current	Protection class	Weight	Frequency inverter
		A		kg	
ND011	357180	11	IP00	2.40	ZAdynpro 011
ND013	357181	13		2.50	ZAdynpro 013
ND017	357182	17		3.30	ZAdynpro 017
ND023	357183	23		4.00	ZAdynpro 023
ND032	357184	32		6.70	ZAdynpro 032
ND110	357196	110		14.00	ZAdyn4B 110
ND180	357197	180		21.00	ZAdyn4B 180

Dimensions mm

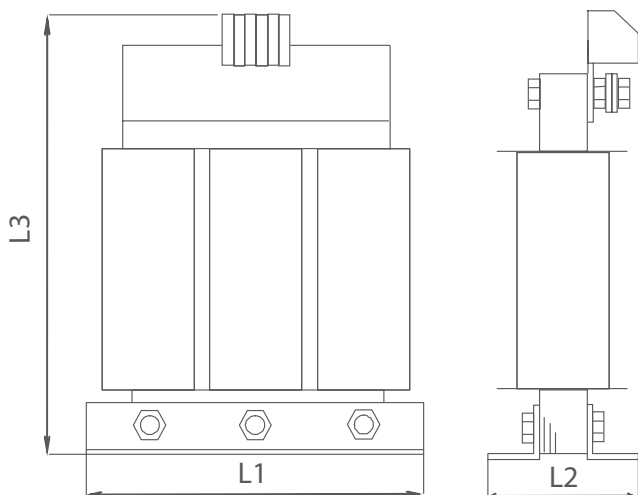

Type	L1	L2	L3
ND011	125	61	135
ND013	125	71	135
ND017	125	71	135
ND023	155	80	160
ND032	155	95	170
ND110	230	150	280
ND180	230	150	305

Radio interference filter FEF



Description

- For ZAdyn4B
- For compliance with the limits required by EN 12015 (interference emission)
- Reduces high-frequency electromagnetic emission

Technical data

Type	Article no.	Nominal current	Protection class	Weight	Frequency inverter
		A		kg	
FEF180KK4D	357199	180	IP20	6.00	ZAdyn4B 110 ZAdyn4B 180

Dimensions mm

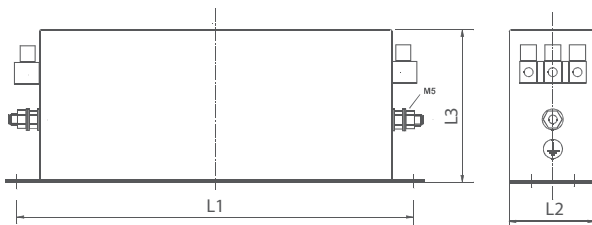

Type	L1	L2	L3
FEF180KK4D	450	130	180

Retrofit kits

Retrofit kit DISCcontrol



Description

- Retrofit kit for operation of permanently excited disc motors with ZAdyn4CS
- Quick frequency inverter replacement in combination with a commonly available elevator controller
- Simple attachment of the incremental encoder and hall sensor
- Fail-safe connection of incremental encoder and hall sensor thanks to 15-pin D-SUB plug
- Extremely safe operation thanks to adjustment of the number of correction magnets on the existing motor type
- Software-supported magnet positioning
- Existing brake resistor can be used furthermore

Scope of delivery

- Attachment kit with incremental encoder and hall sensor
- Magnets for determining the rotor position
- Adhesive and template for magnet assembly
- Assembly instructions

Article no. 357299

Retrofit kit SMART



Description

- Retrofit kit for replacement of the frequency inverter on Schindler Smart type elevator systems based on ZAdyn4CA
- No replacement of the controller
- With incremental encoder for improved travel comfort

Scope of delivery

- Incremental encoder
- Adapter M16 for incremental encoder
- 3 relays (110 VAC) for signal adaptation

Article no. 357281

Retrofit kits

Retrofit incremental encoder with solid shaft

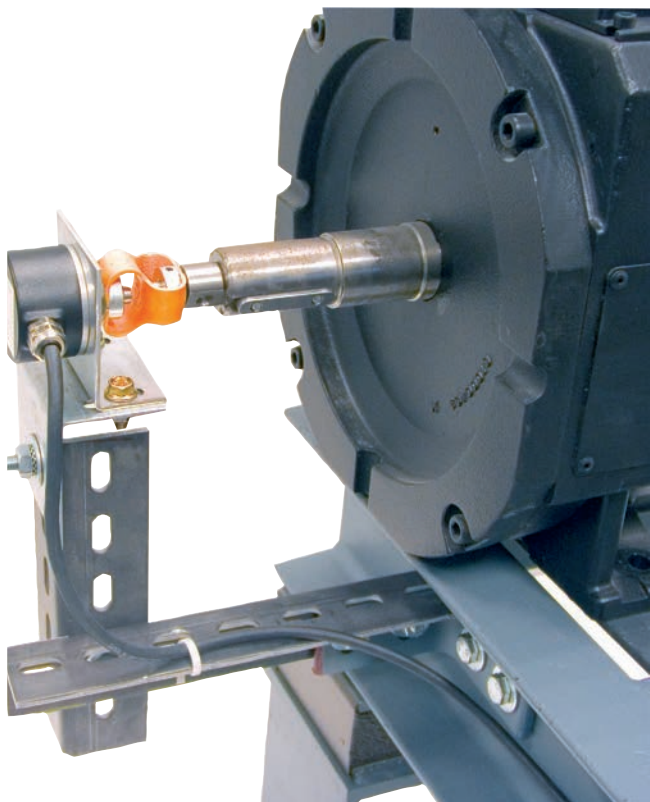

Description

- Retrofit kit for fast and simple mounting of an incremental encoder with solid shaft
- Mounting with and without hand wheel possible
- Prefabricated encoder cable

Scope of delivery

- Incremental encoder
 - Incl. cable with plug D-SUB 15-pin for ZAdyn4C and ZETADYN 3
- Flex coupling
 - Thermoplastic compensation element for connection between incremental encoder and motor shaft
- Adaptor
 - For mounting the flex coupling on the motor shaft
- Motor add-on kit
 - Solid angles and struts for rigid connection to the machine frame or floor



Technical data

Type	Threaded nipple	Operating voltage incremental encoder VDC	Signal shape	Cable length m	Article no.
Retrofit kit incremental encoder	M8	4.75 ... 30	RS422 Inkremental	10.0	70028208
	M10				70028209
	M12				70028210
	M14				70028211
	M16				70028212
	M20				70028327

Information

ZAtop

ZAsyn

ZAdisc

VFD

System components
motors

Control
technology

System components
control
technology

Appendix

Retrofit kits

Retrofit kit incremental encoder with hollow shaft



Description

- Adapter for quick and simple assembly of an incremental encoder with hollow shaft
- Assembly with or without handwheel

Centring thread Motor shaft	Shaft diameter Adapter mm	Article no.
M10	28	70024258
M12		70024259
M16		70024260
M20		70025581

Retrofit kit inductive proximity switches



Description

- Retrofit kit for conversion to contact-less monitoring of the motor brakes by inductive proximity switches

Scope of delivery

- 2 inductive proximity switches
- Connecting cable 3.0 m or 15.0 m

Technical data

Type	Motor type ZAtop	Connection cable length m	Article no.
Retrofit kit proximity switch	SM160.30B	3.0	70028330
	SM160.40B	15.0	70028331
	SM200.15C		
	SM200.20C	3.0	70028332
	SM200.30C		70028333
	SM225.60B	3.0	70028334
		15.0	70028335
	SM250.60B	3.0	70028336
		15.0	70028337
	SM250.80D	3.0	70028338
		15.0	70028339

Control and connection cables ZAdyn4

Brake release monitoring micro switches

- For ZAtop and ZAdisc
- Connection of the micro-switches for the brake release monitoring to the ZAdyn4 frequency inverter
- Prefabricated:
 - Connection side ZAdyn4: plug 5-pin
 - Connection side brake: wire-end sleeves
- Halogen-free



Type	Article no.	Length m	Cable cross section mm ²
L-BL-018-HX-ZA4-AE	00165936-018M	1.8	3 x 0.75
L-BL-03-HX-ZA4-AE	00165936-03M	3.0	
L-BL-05-HX-ZA4-AE	00165936-05M	5.0	
L-BL-10-HX-ZA4-AE	00165936-10M	10.0	
L-BL-15-HX-ZA4-AE	00165936-15M	15.0	
L-BL-20-HX-ZA4-AE	00165936-20M	20.0	
L-BL-25-HX-ZA4-AE	00165936-25M	25.0	

Brake release monitoring inductive proximity switches

- For ZAtop and ZAdisc
- Connection of the inductive proximity switches for the brake release monitoring to the ZAdyn4 frequency inverter
- Prefabricated:
 - Connection side ZAdyn4: plug 5-pin
 - Connection side brake: wire-end sleeves
- Halogen-free



Type	Article no.	Length m	Cable cross section mm ²
L-BL-018-HX-ZA4-AE-INI	00166085-018M	1.8	3 x 0.75
L-BL-03-HX-ZA4-AE-INI	00166085-03M	3.0	
L-BL-05-HX-ZA4-AE-INI	00166085-05M	5.0	
L-BL-10-HX-ZA4-AE-INI	00166085-10M	10.0	
L-BL-15-HX-ZA4-AE-INI	00166085-15M	15.0	
L-BL-20-HX-ZA4-AE-INI	00166085-20M	20.0	
L-BL-25-HX-ZA4-AE-INI	00166085-25M	25.0	

Control and connection cables

ZAdyn4

Brake resistor cable

- Cable to connect the brake resistor BR...-3 to the ZAdyn4 frequency inverter and BR100-BOX
- Prefabricated
- Integrated conductors for temperature monitoring
- Halogen-free



L-BR...-HX-2.5-ZA4
L-BR...-HX-6-ZA4



L-BR...-HX-16-ZA3/4

Frequency inverter type	Type	Article no.	Cable length m	Cable cross section mm ²
ZAdyn4C 011 ZAdyn4C 013 ZAdyn4C 017 ZAdyn4C 023	L-BR-03-HX-2.5-ZA4 L-BR-05-HX-2.5-ZA4	00165932-03M 00165932-05M	3.0 5.0	3 x 2.5 + 2 x 0.5
ZAdyn4C 032 ZAdyn4C 040 ZAdyn4C 050 ZAdyn4C 062 ZAdyn4C 074	L-BR-03-HX-6-ZA4 L-BR-05-HX-6-ZA4	00165933-03M 00165933-05M	3.0 5.0	3 x 6.0 + 2 x 0.5
ZAdyn4B 110 ZAdyn4B 180	L-BR-03-HX-16-ZA3/4 L-BR-05-HX-16-ZA3/4	00165724 00165725	3.0 5.0	3 x 16.0 + 2 x 0.5

Cable BR100-BOX

- Cable for connecting the BR100-BOX to ZAdyn4B 110/180
- Prefabricated
- Integrated wires for temperature monitoring
- Halogen-free



Frequency inverter type	Type	Article no.	Cable length m	Cable cross section mm ²
ZAdyn4B 110/180	L-BR-03-HX-16-BR-BOX	00165953-03M	3.0	3x16.0 + 2x0.5

Connection cable motor temperature monitoring PTC thermistor

- Connection of the PTC to the ZAdyn4 frequency inverter
- Prefabricated:
 - Connection side ZAdyn4: plug 4-pin
 - Connection side motor: wire-end sleeves
- Halogen-free



Type	Article no.	Cable length m	Cable cross section mm ²
L-KL-018-HX-ZA3/4-AE	00165801	1.8	2 x 0.75
L-KL-03-HX-ZA3/4-AE	00165650	3.0	
L-KL-05-HX-ZA3/4-AE	00165846	5.0	
L-KL-10-HX-ZA3/4-AE	00165800	10.0	
L-KL-15-HX-ZA3/4-AE	00165847	15.0	
L-KL-20-HX-ZA3/4-AE	00165801-20M	20.0	
L-KL-25-HX-ZA3/4-AE	00165801-25M	25.0	



Control cable DCP

Standard cables

- Prefabricated:
 - Connection side ZAdyn4: plug 4-pin
 - Connection side elevator controller: wire-end sleeves
- Halogen-free



Type	Article no.	Cable length	Cable cross section
		m	mm ²
L-SL-03-HX-ZA-DCP	00164123	3.0	2 x 2 x 0.25
L-SL-05-HX-ZA-DCP	00165925	5.0	
L-SL-10-HX-ZA-DCP	00164136	10.0	
L-SL-25-HX-ZA-DCP	00164137	25.0	
L-SL-50-HX-ZA-DCP	00164138	50.0	

Control-dependent special cable NEW LIFT

- Prefabricated:
 - Connection side ZAdyn4: plug 4-pin
 - Connection side elevator controller: D-SUB 9-pin
- Halogen-free

Type	Article no.	Cable length	Cable cross section
		m	mm ²
L-SL-03-HX-ZA-DCP-1	00164048	3.0	2 x 2 x 0.25
L-SL-05-HX-ZA-DCP-1	00165926	5.0	
L-SL-10-HX-ZA-DCP-1	00164049	10.0	
L-SL-25-HX-ZA-DCP-1	00164050	25.0	
L-SL-50-HX-ZA-DCP-1	00164051	50.0	

Information

ZAtop

ZAsyn

ZAdisc

VFD

System components motors

Control technology

System components control technology

Appendix

Control and connection cables ZAdyn4

STO control cable

- Activation of the Safe Torque Off (STO) function
- Prefabricated:
 - Connection side ZAdyn4: plug 6-pin
 - Connection side elevator controller: wire-end sleeves
- Halogen-free

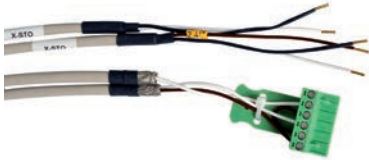

Type	Article no.	Cable length	Cable cross section
		m	mm ²
L-SL-03-HX-ZA4-STO	00165938-03M	3.0	3 x 0.5
L-SL-05-HX-ZA4-STO	00165938-05M	5.0	
L-SL-10-HX-ZA4-STO	00165938-10M	10.0	
L-SL-25-HX-ZA4-STO	00165938-25M	25.0	
L-SL-50-HX-ZA4-STO	00165938-50M	50.0	

Control cable digital inputs

- Activation of the digital inputs through the elevator controller
- Prefabricated:
 - Connection side ZAdyn4: plug, 13-pin
 - Connection side elevator controller: wire-end sleeves
- Halogen-free



Type	Article no.	Cable length	Cable cross section
		m	mm ²
L-SL-03-HX-ZA4-IN	00165934-03M	3.0	12 x 0.5
L-SL-05-HX-ZA4-IN	00165934-05M	5.0	
L-SL-10-HX-ZA4-IN	00165934-10M	10.0	
L-SL-25-HX-ZA4-IN	00165934-25M	25.0	
L-SL-50-HX-ZA4-IN	00165934-50M	50.0	

Control cable digital outputs

- Evaluation of the digital outputs through the elevator controller
- Prefabricated:
 - Connection side ZAdyn4: plug, 10-pin
 - Connection side elevator controller: wire-end sleeves
- Halogen-free



Type	Article no.	Cable length	Cable cross section
		m	mm ²
L-SL-03-HX-ZA4-OUT	00165935-03M	3.0	10 x 0.5
L-SL-05-HX-ZA4-OUT	00165935-05M	5.0	
L-SL-10-HX-ZA4-OUT	00165935-10M	10.0	
L-SL-25-HX-ZA4-OUT	00165935-25M	25.0	
L-SL-50-HX-ZA4-OUT	00165935-50M	50.0	

Plug set ST4C

- Consisting of all connectors for connecting the ZAdyn4

Article no. 357258

Connection cables ZAdynpro

Brake resistor cable

- Cable to connect the brake resistor BR..-3 to the ZAdynpro frequency inverter
- Prefabricated
- Integrated conductors for temperature monitoring
- Halogen-free



Frequency inverter type	Type	Article no.	Cable length m	Cable cross section mm ²
ZAdynpro 011-032	L-BR-03-HX-2.5-ZAp	00166112-03M	3.0	3 x 6.0 + 2 x 0.5
	L-BR-03-HX-6-ZAp	00166113-03M	3.0	3 x 6.0 + 2 x 0.5

Control and connection cables ZAsbc4

Brake control

- For ZAtop and ZAdisc
- Connection of the brake coils on ZAsbc4
- Prefabricated:
 - Connection side ZAsbc4: plug 4-pin
 - Connection side brake: wire-end sleeves
- Halogen-free



Type	Article no.	Cable length m	Cable cross section mm ²
L-BA-018-HX-SBC4-AE	00166059-018M	1.8	2 x 2 x 1.0
L-BA-03-HX-SBC4-AE	00166059-03M	3.0	
L-BA-05-HX-SBC4-AE	00166059-05M	5.0	
L-BA-10-HX-SBC4-AE	00166059-10M	10.0	
L-BA-15-HX-SBC4-AE	00166059-15M	15.0	
L-BA-20-HX-SBC4-AE	00166059-20M	20.0	
L-BA-25-HX-SBC4-AE	00166059-25M	25.0	

ZAsbc4C wiring harness

- 5-part prefabricated wiring harness for connecting the elevator controller to ZAsbc4C
 - Supply voltage
 - Monitoring safety circuit
 - Activation, emergency operation and brake test
 - Test overvoltage protection
 - Status monitoring
- Prefabricated
 - Connection side ZAsbc4: plugs
 - Connection side controller: wire-end sleeves

Type	Article no.	Cable length m	Cable cross section mm ²
LS-SBC4-03-HX-ST	357289-03M	3.0	3 x 1.5 (Supply)
LS-SBC4-05-HX-ST	357289-05M	5.0	5 x 0.75 (Monitoring, safety circuit)
LS-SBC4-10-HX-ST	357289-10M	10.0	3 x 0.75 (Activation, emergency operation and brake test)
LS-SBC4-25-HX-ST	357289-25M	25.0	2 x 0.75 (Test overvoltage protection)
LS-SBC4-50-HX-ST	357289-50M	50.0	2 x 0.75 (Status monitoring)

Connection cables ZApad



ZApad data cable

- Connection of the ZApad to frequency inverter type ZETADYN / ZAdyn. recuperation units type ZAreC and evacuation units type EVAC 3
- Double plug RJ45
- Halogen-free

Type	Article no.	Cable length m
L-DL-005-HX-RJ45	00159973	0.5
L-DL-10-HX-RJ45	00159967	10.0
L-DL-25-HX-RJ45	00159968	25.0
L-DL-50-HX-RJ45	00164122	50.0



Modular coupler RJ

- Coupler to connect the cable type L-DL-...-HX-RJ45
- Double jack RJ45

Article no. 00155975



ZAmOn data cable

- Connection of the ZApad to a notebook or PC to be able to use the ZAmOn software
- USB 2.0 connection line A/B
- Halogen-free
- Length: 1.8 m
- Type: L-DL-018-HX-USB-A-B

Article no. 00159946

ZAreC wiring harness

LS-ZAreC4C-...-HX-...-ZA3/4

- 2-part prefabricated wiring harness for connecting the ZAreC to ZETADYN 3 and ZAdyn4:
- Signal transmission ZAreC - ZETADYN 3 / ZAdyn4
- Connection DC-link voltage ZAreC - ZETADYN 3 / ZAdyn4

Type	Article no.	Frequency inverter	Cable length m	Cable cross section mm ²
LS-ZAreC4C-03-HX-023-ZA3/4	357276	ZETADYN 3BF011-023 ZETADYN 3C011-023	3.0	6 x 0.75 (Signals) 3 x 2.5 (DC-link)
LS-ZAreC4C-05-HX-023-ZA3/4	357277	ZAdyn4C 011-023	5.0	6 x 0.75 (Signals) 3 x 2.5 (DC-link)
LS-ZAreC4C-03-HX-074-ZA3/4	357278	ZETADYN 3BF032-074 ZETADYN 3C032-074	3.0	6 x 0.75 (Signals) 3 x 6.0 (DC-link)
LS-ZAreC4C-05-HX-074-ZA3/4	357279	ZAdyn4C 032-074	5.0	6 x 0.75 (Signals) 3 x 6.0 (DC-link)

EVAC battery set and wiring harness

Battery set EVAC-BATT



Description

- Selection is made depending on the nominal current of the motor and the duration or number of evacuations

Technical data

Type	Article no.	Rated voltage VDC	Rated capacity Ah	Rated current A	Weight kg
032-120-24	357234	120	24.0	32	2 x 50
050-120-24	357235	120	24.0	50	2 x 50
074-120-24	357236	120	24.0	74	2 x 50
032-180-7.2	357238	180	7.2	32	24 + 26
032-180-24	357242	180	24.0	32	3 x 50
050-180-24	357243	180	24.0	50	3 x 50
074-180-24	357244	180	24.0	74	3 x 50

Dimensions mm

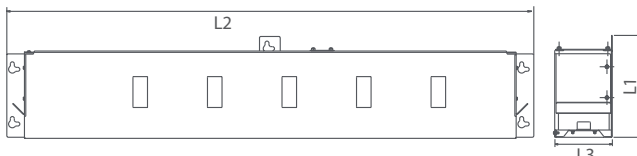

Type	L1	L2	L3
032-120-24	231	1195	130
050-120-24			
074-120-24			
032-180-7.2	205	948	116
032-180-24	231	1195	130
050-180-24			
074-180-24			

EVAC 3C wiring harness

LS-EVAC3C-...-HX-...-ZA3/4

- 3-part wiring harness for connecting the ZETADYN 3 / ZAdyn4 and the EVAC BATT to EVAC 3C:
 - Power supply of the ZETADYN 3 / ZAdyn4 by EVAC 3C
 - Signal transmission EVAC 3C ⇔ ZETADYN 3 / ZAdyn4
 - Connection battery set EVAC BATT

Type	Article no.	Cable length m	Cable cross-section EVAC 3C ⇔ ZETADYN 3 / ZAdyn4 mm ²	Cable cross-section EVAC 3C ⇔ EVAC BATT mm ²
LS-EVAC3C-03-HX-032-ZA3/4	357239	3.0	4 x 6.0 (supply) 4 x 0.5 (signals)	3 x 6.0 + 2 x 0.5
LS-EVAC3C-03-HX-050-ZA3/4	357240	3.0	4 x 10.0 (supply) 4 x 0.5 (signals)	3 x 6.0 + 2 x 0.5
LS-EVAC3C-03-HX-074-ZA3/4	357241	3.0	4 x 25.0 (supply) 4 x 0.5 (signals)	4 x 10.0 + 2 x 1.0

LS-EVAC3C-...-HX-ST

- 3-part wiring harness for connecting the elevator controller and the main switch monitoring to EVAC 3C:
 - Control power supply through EVAC 3C
 - Signal transmission EVAC 3C ⇔ Controller
 - Main switch monitoring

Type	Article no.	Cable length m	Cable cross-section EVAC 3C ⇔ Controller mm ²	Cable cross-section EVAC 3C ⇔ Main switch mm ²
LS-EVAC3C-03-HX-ST	357247	3.0	3 x 1.5 (supply) 3 x 0.75 (signals)	2 x 0.75 (monitoring)
LS-EVAC3C-10-HX-ST	357248	10.0	3 x 1.5 (supply) 3 x 0.75 (signals)	2 x 0.75 (monitoring)

Motor cables

Standard

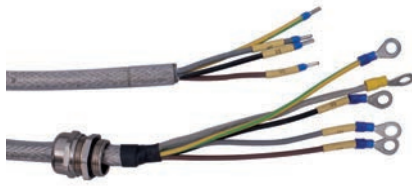

For motor type ZAtop, ZAsyn SM860 and VFD

- Cable for connecting the motor to frequency inverter type ZETADYN / ZAdyn
- Including cable gland
- Prefabricated:
 - Connection side motor: ring cable lug
 - Connection side ZETADYN / ZAdyn: wire-end sleeves

Rated current*	Cable cross section	Cable gland	Ring cable lug for terminal board	Fits motor	Cable length	Type	Article no.
A	mm ²				m		
20	4 x 2.5	M25	M6	VFD132	5.0	L-ML-05-YY-2.5-M6-AE	356035-05M
					10.0	L-ML-10-YY-2.5-M6-AE	356035-10M
					15.0	L-ML-15-YY-2.5-M6-AE	356035-15M
					20.0	L-ML-20-YY-2.5-M6-AE	356035-20M
					25.0	L-ML-25-YY-2.5-M6-AE	356035-25M
			M8	SM200.40 SM225 VFD160	5.0	L-ML-05-YY-2.5-M8-AE	356038-05M
					10.0	L-ML-10-YY-2.5-M8-AE	356038-10M
					15.0	L-ML-15-YY-2.5-M8-AE	356038-15M
					20.0	L-ML-20-YY-2.5-M8-AE	356038-20M
					25.0	L-ML-25-YY-2.5-M8-AE	356038-25M
25	4 x 4.0	M32	M6	VFD132	5.0	L-ML-05-YY-4-M6-AE	356036-05M
					10.0	L-ML-10-YY-4-M6-AE	356036-10M
					15.0	L-ML-15-YY-4-M6-AE	356036-15M
					20.0	L-ML-20-YY-4-M6-AE	356036-20M
					25.0	L-ML-25-YY-4-M6-AE	356036-25M
			M8	SM200.40 SM225 SM860 VFD160	5.0	L-ML-05-YY-4-M8-AE	356039-05M
					10.0	L-ML-10-YY-4-M8-AE	356039-10M
					15.0	L-ML-15-YY-4-M8-AE	356039-15M
					20.0	L-ML-20-YY-4-M8-AE	356039-20M
					25.0	L-ML-25-YY-4-M8-AE	356039-25M
35	4 x 6.0	M32	M6	VFD132	5.0	L-ML-05-YY-6-M6-AE	356037-05M
					10.0	L-ML-10-YY-6-M6-AE	356037-10M
					15.0	L-ML-15-YY-6-M6-AE	356037-15M
					20.0	L-ML-20-YY-6-M6-AE	356037-20M
					25.0	L-ML-25-YY-6-M6-AE	356037-25M
			M8	SM200.40 SM225 SM250 SM860 VFD180	5.0	L-ML-05-YY-6-M8-AE	356040-05M
					10.0	L-ML-10-YY-6-M8-AE	356040-10M
					15.0	L-ML-15-YY-6-M8-AE	356040-15M
					20.0	L-ML-20-YY-6-M8-AE	356040-20M
					25.0	L-ML-25-YY-6-M8-AE	356040-25M
50	4 x 10.0	M40	M8	SM200.40 SM225 SM250 SM860 VFD160-225	5.0	L-ML-05-YY-10-M8-AE	356041-05M
					10.0	L-ML-10-YY-10-M8-AE	356041-10M
					15.0	L-ML-15-YY-10-M8-AE	356041-15M
					20.0	L-ML-20-YY-10-M8-AE	356041-20M
					25.0	L-ML-25-YY-10-M8-AE	356041-25M
63	4 x 16.0	M40	M8	SM200.40 SM225 SM250 SM860 VFD180-250	5.0	L-ML-05-YY-16-M8-AE	356042-05M
					10.0	L-ML-10-YY-16-M8-AE	356042-10M
					15.0	L-ML-15-YY-16-M8-AE	356042-15M
					20.0	L-ML-20-YY-16-M8-AE	356042-20M
					25.0	L-ML-25-YY-16-M8-AE	356042-25M

* The stated rated currents are rated according to DIN VDE 0298-4 for laying system B2 and a max. ambient temperature of 40 ° C.



Rated current*	Cable cross section	Cable gland	Ring cable lug for terminal board	Fits motor	Cable length	Type	Article no.
A	mm ²				m		
80	4 x 25.0	M50	M8	SM225 SM250 SM860 VFD180-250	5.0	L-ML-05-YY-25-M8-AE	356043-05M
					10.0	L-ML-10-YY-25-M8-AE	356043-10M
					15.0	L-ML-15-YY-25-M8-AE	356043-15M
					20.0	L-ML-20-YY-25-M8-AE	356043-20M
					25.0	L-ML-25-YY-25-M8-AE	356043-25M
100	4 x 35.0	M50	M8	SM225	5.0	L-ML-05-YY-35-M8-AE	356044-05M
					10.0	L-ML-10-YY-35-M8-AE	356044-10M
					15.0	L-ML-15-YY-35-M8-AE	356044-15M
					20.0	L-ML-20-YY-35-M8-AE	356044-20M
					25.0	L-ML-25-YY-35-M8-AE	356044-25M
			M10	SM250 SM860 VFD180-250	5.0	L-ML-05-YY-35-M10-AE	356033-05M
					10.0	L-ML-10-YY-35-M10-AE	356033-10M
					15.0	L-ML-15-YY-35-M10-AE	356033-15M
					20.0	L-ML-20-YY-35-M10-AE	356033-20M
					25.0	L-ML-25-YY-35-M10-AE	356033-25M
125	4 x 50.0	M50	M10	SM250 SM860 VFD180-250	10.0	L-ML-10-YY-50-M10-AE	356068-10M
160	4 x 70.0	M50	M12	SM250	10.0	L-ML-10-YY-70-M12-AE	356034-10M
					20.0	L-ML-20-YY-70-M12-AE	356034-20M
200	4 x 95.0	M63	M12	SM250	10.0	L-ML-10-YY-95-M12-AE	356045-10M
					20.0	L-ML-20-YY-95-M12-AE	356045-20M

* The stated rated currents are rated according to DIN VDE 0298-4 for laying system B2 and a max. ambient temperature of 40° C.

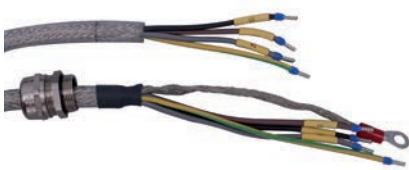

For motor type ZAdisc, ZAsyn SM700 and externally procured motors

- Cable for connecting the motor to frequency inverter type ZAdyn
- Including cable gland
- Prefabricated:
 - Connection side motor: wire-end sleeves
 - Connection side ZAdyn: wire-end sleeves

Rated current*	Cable cross section	Cable gland	Fits motor	Cable length	Type	Article no.
A	mm ²			m		
20.0	4 x 2.5	M25	SL506 SL510 SM700	10.0	L-ML-10-YY-2.5-AE-AE	356016-10M
25.0	4 x 4.0	M32	SL506 SL510 SM700	10.0	L-ML-10-YY-4-AE-AE	356017-10M
35.0	4 x 6.0	M32	SL506 SL510 SM700	10.0	L-ML-10-YY-6-AE-AE	356018-10M
50.0	4 x 10.0	M25	SL510 SM700	10.0	L-ML-10-YY-10-AE-AE	356019-10M
63.0	4 x 16.0	M40	SL510 SM700	10.0	L-ML-10-YY-16-AE-AE	356020-10M
80.0	4 x 25.0	M50	SM700	10.0	L-ML-10-YY-25-AE-AE	356021-10M

* The stated rated currents are rated according to DIN VDE 0298-4 for laying system B2 and a max. ambient temperature of 40° C.

Motor cables

Halogen-free

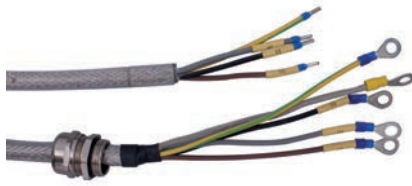

For motor type ZAtop, ZAsyn SM860 and VFD

- Cable for connecting the motor to frequency inverter type ZETADYN / ZAdyn
- Including cable gland
- Prefabricated:
 - Connection side motor: ring cable lug
 - Connection side ZETADYN / ZAdyn: wire-end sleeves

Rated current*	Cable cross section	Cable gland	Ring cable lug for terminal board	Fits motor	Cable length	Type	Article no.
A	mm ²				m		
20	4 x 2.5	M25	M8	SM200.40 SM225 VFD160	5.0	L-ML-05-HX-2.5-M8-AE	356056-05M
					10.0	L-ML-10-HX-2.5-M8-AE	356056-10M
					15.0	L-ML-15-HX-2.5-M8-AE	356056-15M
					20.0	L-ML-20-HX-2.5-M8-AE	356056-20M
					25.0	L-ML-25-HX-2.5-M8-AE	356056-25M
25	4 x 4.0	M32	M8	SM200.40 SM225 VFD160	5.0	L-ML-05-HX-4-M8-AE	356057-05M
					10.0	L-ML-10-HX-4-M8-AE	356057-10M
					15.0	L-ML-15-HX-4-M8-AE	356057-15M
					20.0	L-ML-20-HX-4-M8-AE	356057-20M
					25.0	L-ML-25-HX-4-M8-AE	356057-25M
35	4 x 6.0	M32	M8	SM200.40 SM225 SM250 VFD160	5.0	L-ML-05-HX-6-M8-AE	356058-05M
					10.0	L-ML-10-HX-6-M8-AE	356058-10M
					15.0	L-ML-15-HX-6-M8-AE	356058-15M
					20.0	L-ML-20-HX-6-M8-AE	356058-20M
					25.0	L-ML-25-HX-6-M8-AE	356058-25M
50	4 x 10.0	M40	M8	SM200.40 SM225 SM250 SM860 VFD160-225	5.0	L-ML-05-HX-10-M8-AE	356059-05M
					10.0	L-ML-10-HX-10-M8-AE	356059-10M
					15.0	L-ML-15-HX-10-M8-AE	356059-15M
					20.0	L-ML-20-HX-10-M8-AE	356059-20M
					25.0	L-ML-25-HX-10-M8-AE	356059-25M
63	4 x 16.0	M40	M8	SM200.40 SM225 SM250 VFD180-250	5.0	L-ML-05-HX-16-M8-AE	356060-05M
					10.0	L-ML-10-HX-16-M8-AE	356060-10M
					15.0	L-ML-15-HX-16-M8-AE	356060-15M
					20.0	L-ML-20-HX-16-M8-AE	356060-20M
					25.0	L-ML-25-HX-16-M8-AE	356060-25M
80	4 x 25.0	M50	M8	SM225 SM250 VFD180-250	5.0	L-ML-05-HX-25-M8-AE	356061-05M
					10.0	L-ML-10-HX-25-M8-AE	356061-10M
					15.0	L-ML-15-HX-25-M8-AE	356061-15M
					20.0	L-ML-20-HX-25-M8-AE	356061-20M
					25.0	L-ML-25-HX-25-M8-AE	356061-25M
100	4 x 35.0	M50	M10	SM250	5.0	L-ML-05-HX-35-M10-AE	356062-05M
					10.0	L-ML-10-HX-35-M10-AE	356062-10M
					15.0	L-ML-15-HX-35-M10-AE	356062-15M
					20.0	L-ML-20-HX-35-M10-AE	356062-20M
					25.0	L-ML-25-HX-35-M10-AE	356062-25M

* The stated rated currents are rated according to DIN VDE 0298-4 for laying system B2 and a max. ambient temperature of 40° C.



Connection box for shielded motor cables

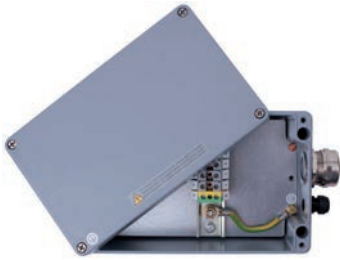

Description

- Simple and EMC-conform extension of ZIEHL-ABEGG motor cables
- Cable glands on both sides
- Wire cross section from 4 x 2.5 mm² to 4 x 16 mm²
- Dimensions without cable glands
(W x H x T) in mm: 260 x 160 x 91

Article no. 70026751

EMC cable glands



Type	Article no.	EMC lock nut** Article no.	Ø Motor cable mm
M25 x 1.5	02002881	02002803	4 x 2.5
M32 x 1.5	02002184	02002198	4 x 4.0 4 x 6.0
M40 x 1.5	02002185	02002199	4 x 10 4 x 16
M50 x 1.5	02002186	02002200	4 x 25 4 x 35

* Reducing sealing ring (Article no. 02008019) required

** With cutting edge for secure contacting even on painted housings

Information

ZAtop

ZAsyn

ZAdisc

VFD

System compo-
nents motorsControl
technologySystem com-
ponents control
technology

Appendix

Encoder cables

Standard



For absolute encoder (synchronous motors)

- Cable for connecting the absolute encoder to frequency inverter type ZAdyn / ZETADYN
- For ZAtop, ZAsyn and ZAdisc type motors
- Prefabricated

Encoder type	Frequency inverter	Encoder connection	Frequency inverter connection	Cable cross section	Cable length	Type	Article no.
				mm ²			
ECN1313	ZAdyn4	Jack 12 pin	Plug D-SUB 15-pin	6 x 2 x 0.14	1.2	-	00201388-1.2M
ECN113 ECN1313	ZETADYN 3 ZAdyn4	Jack M16 x 0.75 (KV120)	Plug D-SUB 15-pin	6 x 2 x 0.14	5.0	L-GL-05-YY-ZA-ECN	00159923
					10.0	L-GL-10-YY-ZA-ECN	00155050
					15.0	L-GL-15-YY-ZA-ECN	00166102
					20.0	L-GL-20-YY-ZA-ECN	00166103
					25.0	L-GL-25-YY-ZA-ECN	00159925
ERN1387	ZETADYN 3 ZAdyn4	Jack M23 x 1	Plug D-SUB 15-pin	8 x 2 x 0.14	10.0	L-GL-10-YY-ZA3-ERN1387	00159964
						L-GL-10-YY-ZA4-ERN1387	00165948-10M

For incremental encoder (asynchronous motors)

- Cable to connect the incremental encoder to frequency inverter type ZAdyn / ZETADYN
- For VFD type motors
- Prefabricated

Encoder type	Frequency inverter	Encoder connection	Frequency inverter connection	Cable cross section	Cable length	Type	Article no.
				mm ²			
ET2S	ZETADYN 3 ZAdyn4*	Jack M16 x 0.75 (KV120)	Plug D-SUB 9-pin	6 x 0.14	10.0	L-GL-10-YY-ZA-ET2S	00159927

* ZAdyn4 only with D-SUB 9 ⇒ D-SUB 15 adapter (article no. 00165930-004M)

Halogen-free

For absolute encoders (synchronous motors)

- Cable to connect the absolute encoder to frequency inverter type ZAdyn / ZETADYN
- For ZAtop, ZAsyn and ZAdisc type motors
- Prefabricated
- Halogen-free

Encoder type	Frequency inverter	Encoder connection	Frequency inverter connection	Cable cross section	Cable length	Type	Article no.
				mm ²			
ECN113 ECN1313	ZETADYN 3 ZAdyn4	Jack M16 x 0.75 (KV120)	Plug D-SUB 15-pin	6 x 2 x 0.14	1.8	L-GL-018-HX-ZA-ECN	00165713
					3.0	L-GL-03-HX-ZA-ECN	00165644
					5.0	L-GL-05-HX-ZA-ECN	00166095
					10.0	L-GL-10-HX-ZA-ECN	00165615
					15.0	L-GL-15-HX-ZA-ECN	00157818
					20.0	L-GL-20-HX-ZA-ECN	00166104
					25.0	L-GL-25-HX-ZA-ECN	00165616



Encoder cables

Adapter

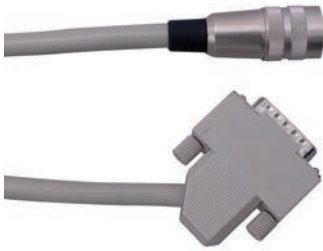

Adapter for encoder cables

- Connection of cables with D-SUB plug to ZAdyn4
- Prefabricated
- Halogen-free

Manufacturer:	Encoder	Connection side encoder cable	Frequency in-verter connection	Cable cross section mm ²	Cable length m	Type	Article no.
ZIEHL-ABEGG	Incremental	Jack D-SUB 9-pin	Plug D-SUB 15-pin	6 x 2 x 0.14	0.4	L-GL-004-HX-ZAS-ASM-9-15	00165930-004M
	Incremental	Jack D-SUB 15-pin	Plug D-SUB 9-pin			L-GL-004-HX-ZAS-ASM-15-9	00165931-004M
Thyssen	Absolute (EnDat)	Jack D-SUB 15-pin	Plug D-SUB 15-pin			L-GL-004-HX-THY-ZA-ECN	00166089-004M
	Incremental	Jack D-SUB 9-pin	Plug D-SUB 15-pin			L-GL-004-HX-THY-ZA-ASM	00166090-004M

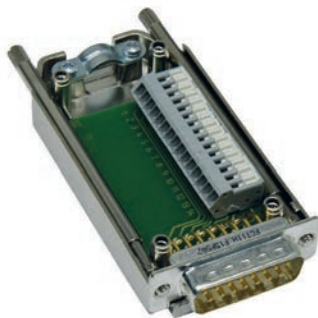

Plug connector X-ENC15

- Adapter plug for connecting absolute encoder to ZAdyn4
- D-SUB 15-pin to plug-in connection

Article no. **00152676**

Adapter cable encoder ↔ encoder cable



Encoder type	Article no.	Cable length m	Encoder con-nection	Encoder cable con-nection	Cable cross section mm ²
ECN 1313	00159930	0.245	Jack 12 pin	Plug M16 x 0.75 (SV120)	12 x 0.14
	00159953	0.560			12 x 0.14
	00159933	0.245			12 x 0.14
ERN 1387	00159931	0.245	Jack 14 pin	Plug M16 x 0.75 (SV120)	12 x 0.14
	00159934	0.245			14 x 0.14
ERN 1326	00159942	0.245	Jack 16 pin	Plug M23 x 1	16 x 0.14

Encoder cables

Extension cables

- For incremental encoder and absolute encoder with connection D-SUB 15-pin*
- Prefabricated
- Only in combination with encoder cable

Connection side encoder cable	Frequency inverter connection	Cable cross section mm ²	Cable length m	Type	Article no.
Jack D-SUB 15-pin	Plug D-SUB 15-pin	6 x 2 x 0.25	5.0	L-GL-05-YY-ZA-SYN-EXT	00159952-05M
			10.0	L-GL-10-YY-ZA-SYN-EXT	00159952
Jack M16 x 0.75 (KV120)	Plug M16 x 0.75 (SV120)	6 x 2 x 0.14	10.0	L-GL-10-HX-ECN-EXT-KV120	00165665-10M

* for incremental encoder with connection D-SUB 9-pin the adapter article no. 00165930-004M is required in addition

For frequency inverters from other manufacturers

For absolute encoders (synchronous motors)

- Cable to connect the absolute encoder to frequency inverters from other manufacturers
- For ZAtop, ZAsyn and ZAdisc type motors
- Prefabricated

Encoder type	Frequency inverter	Encoder connection	Frequency inverter connection	Cable cross section mm ²	Cable length m	Type	Article no.
ECN113 ECN1313	Arkel Step	Jack M16 x 0.75 (KV120)	Plug D-SUB 15-pin	6 x 2 x 0.14	10.0	L-GL-10-YY-ARKEL/STEP-ECN	00166052-10M
			FUJI		Plug 16-pin MC1.5 / Phoenix	5.0	L-GL-05-YY-FUJI-LM1-ENC L-GL-05-YY-FUJI-LM2-ENC
	10.0					L-GL-10-YY-FUJI-LM1-ENC L-GL-10-YY-FUJI-LM2-ENC	00165827 00166097-10M
	KEB					Plug D-SUB 15-pin	5.0
			10.0		L-GL-10-YY-KEB-F5-ENC		00159734
	Schindler		Plug D-SUB 15-pin		5.0	L-GL-05-YY-SCH-ENC	00159922
					10.0	L-GL-10-YY-SCH-ENC	00159951
independent	Wire-end sleeves	20.0	L-GL-20-YY-SCH-ENC	00159954			
ERN1387	GEBFRAN / SIEI	Plug D-SUB 15-pin	Wire-end sleeves	10.0	L-GL-10-YY-ECN/ERN-AE	02013478-10M	
			Plug D-SUB 15-pin	10.0	L-GL-10-YY-SIEI-ERN1387	00159941	



Incremental encoder

Hollow shaft



Description

- For motor types VFD and other asynchronous motors
- Signal shape: sine or square
- Speed: max. 3500 rpm
- Phase shift: 90°
- With prefabricated connection cable
- Protection class: IP54

Type	Article no.	Shaft diameter mm	Signal shape	Resolution ppr	Signal tracks	Operating voltage VDC	Frequency inverter connection	Cable length m	For frequency inverter
ET2R-1024/28/05V	359010	28	TTL	1024	A. B. /A. /B	5.0	Wire-end sleeves	10.0	-
ET2R-1024/28/05V-1	359026		TTL	1024	A. B. /A. /B. N	5.0	D-SUB 9-pin	10.0	ZETADYN / ZAdyn*
ET2S-1024/28/05V-15	02014700		1 V _{SS}	1024	A. B. /A. /B	5.0	D-SUB 15-pin	10.0	ZETADYN** / ZAdyn
ET2R-1024/28/30V	359004		HTL	1024	A. B	10...30	Wire-end sleeves	10.0	-
ET2R-2500/28/05V-1	359023	38	TTL	2500	A. B. /A. /B. N	5.0	D-SUB 9-pin	10.0	ZETADYN / ZAdyn*
ET2R-1024/38/05V	359011		TTL	1024	A. B. /A. /B	5.0	Wire-end sleeves	10.0	-
ET2R-1024/38/05V-1	359027		TTL	1024	A. B. /A. /B. N	5.0	D-SUB 9-pin	10.0	ZETADYN / ZAdyn*
ET2S-1024/38/05V-15	02014701		1 V _{SS}	1024	A. B. /A. /B	5.0	D-SUB 15-pin	10.0	ZETADYN** / ZAdyn
ET2S-1024/38/05V-2	02006794		1 V _{SS}	1024	A. B. /A. /B	5.0	M16 x 0.75 (SV120) 12-pin	0.5	-
ET2R-1024/38/30V	359005		HTL	1024	A. B	10...30	Wire-end sleeves	10.0	-
ET2R-2500/38/05V-1	359024		TTL	2500	A. B. /A. /B. N	5.0	D-SUB 9-pin	10.0	ZETADYN / ZAdyn*
ET2R-4096/38/05V-1	00037299		TTL	4096	A. B. /A. /B. N	5.0	D-SUB 9-pin	10.0	ZETADYN / ZAdyn*
ET2R-1024/42/05V	359012	42	TTL	1024	A. B. /A. /B	5.0	Wire-end sleeves	10.0	-
ET2R-1024/42/05V-1	359028		TTL	1024	A. B. /A. /B. N	5.0	D-SUB 9-pin	10.0	ZETADYN / ZAdyn*
ET2R-1024/42/30V	359006		HTL	1024	A. B	10...30	Wire-end sleeves	10.0	-
ET2R-2500/42/05V-1	359025		TTL	2500	A. B. /A. /B. N	5.0	D-SUB 9-pin	10.0	ZETADYN / ZAdyn*

* ZAdyn4 and ZAdynpro only with D-SUB 9 ⇔ D-SUB 15 adapter (article no. 00165930-004M)

** ZETADYN 2 and ZETADYN 3 (older than May 2012) only with D-SUB 15 ⇔ D-SUB 9 adapter (article no. 00165931-004M)

Incremental encoder

Solid shaft



Description

- For VFD motor types and other asynchronous motors
- Signal shape: square
- Speed: max. 3500 rpm
- Phase shift: 90°
- With prefabricated connection cable
- Protection class: IP54

Type	Article no.	Shaft diameter mm	Signal shape	Resolution ppr	Signal tracks	Operating voltage VDC	Frequency inverter connection	Cable length m	For frequency inverter
ET2R-1024/10/30V	359020	10	 HTL	1024	A. B	10...30	Wire-end sleeves	10.0	-
ERN1321	02010592	9.25 Cone 1:10	 TTL	4096	A. B. /A. /B	5.0	Board plug 12 pin	-	-



Absolute encoder / adapter cables

Hollow shaft



Description

- For ZAtop motor type
- Signal shape speed: sine
- Speed: max. 3500 rpm
- Phase shift: 90°
- With prefabricated connection cable
- Protection class: IP64

Type	Article no.	Shaft diameter mm	Interface absolute value	Resolution ppr	Signal tracks	Operating voltage VDC	Connection	Cable length m
ECN113 EnDat 2048 Hiatus	01009635	50	EnDat 01	2048	A. B. /A. /B	5.0	M16 x 1 (SV120) 12-pin	0.5
ECN113 EnDat 17pol.	359003		EnDat 01				M23 17-pin	
ECN113 SSI 2048	359000		SSI				M16 x 0.75 (SV120) 12-pin	



Solid shaft



Absolute encoder with solid shaft

- For ZAtop, ZAsyn and ZAdisc motor types
- Signal shape speed: sine
- Speed: max. 3500 rpm
- Phase shift: 90°
- Without connection cable
- Protection class: IP40

Type	Article no.	Shaft diameter mm	Interface absolute value	Resolution ppr	Signal tracks	Operating voltage VDC	Connection
ECN1313 EnDat 2048 Hiatus	02014378-E	9.25	EnDat 01	2048	A, B, /A, /B	5.0	Board plug 12 pin
ECN1313 SSI 2048 Hiatus	02011423	Cone 1:10	SSI				

Type	Article no.	Shaft diameter mm	Interface absolute value	Resolution ppr	Signal tracks	Operating voltage VDC	Connection
ERN 1387 Z 2048	02013477	9.25 Cone 1:10	Z* 	2048	A, B, /A, /B	5.0	Board plug 14 pin
ERN 1326 UVW 4096	02011534	9.25 Cone 1:10	U, V, W	4096	A, B, /A, /B	5.0	Board plug 16 pin
ERN 1326 UVW 8192	02008298			8192			Board plug 16 pin

* 1 sine period / revolution

Information

ZAtop

ZAsyn

ZAdisc

VFD

System components motors

Control technology

System components control technology

Appendix



Software ZAMon

ZAMon

The perfect tool for diagnosing elevator systems and managing of parameters. ZAMon enables fast and simple access to all parameters and functions of the frequency inverters and recuperation units from ZIEHL-ABEGG.

ZAMon provides the suitable software module for every application:



Parameter	Value	Unit
...



The functions of ZAMon

- Time-optimised start-up of the frequency inverter type ZAdyn and the recuperation unit ZRec4C
- Analysis and optimisation of the travel curve
- Fast diagnosis of weak points such as rail joints, door lock interruptions or communication problems to the elevator control system
- Back-up and management of the parameters
- Creation of documents for documentation

Module "Display"

- Remote control of the frequency inverter or recuperation unit via Notebook

Module "Recorder"

Recording of travel curves for diagnostic purposes

- 4 analogue measuring channels
- 1 digital measuring channel
- Free assignment of the measuring channels with measuring functions
- Back-up of recordings
- Comparison of measurements
- FFT analysis
- Mathematic analysis functions

Module "Parameters"

Management of parameter

- Clear display of menus and parameters
- Editing of parameters in real time
- Saving parameters
- Printing of parameter lists
- Printing of error lists
- Loading of saved parameter sets into the frequency inverter or into the recuperation unit
- Comparison of parameters
- Loading installation and motor data from calculations created in the ZAlift calculation software

"Oszi" module

Realtime recording of travel curves for diagnosis purposes

- 4 analogue measurement channels
- Free assignment of measurement channels with measurement functions
- Save the Oszi-recordings

ZAMon is available as a free of charge download on the ZIEHL-ABEGG homepage.



General notes

The information and data contained in this catalogue were composed to the best of our best ability and do not absolve the user from its duty to check the suitability of the products with respect to its intended application.

The customer is obligated to inform the supplier about general information concerning the intended use, the type of installation, the operating conditions and any other conditions that need to be taken into consideration if the order is not based on catalogue information.

ZIEHL-ABEGG SE reserves the right to make design changes, which are used for continuous technical improvement.

This catalogue contains information for your guidance. No guarantee is provided with regard to the accuracy of all information and no legal claims may be derived from this. Reproduction of this information, or extracts thereof, is permitted only with written approval.

Copyright

ZIEHL-ABEGG SE reserves in its entirety the copyright of this catalogue. The catalogue is intended for proper use as intended and neither the catalogue, its content nor extracts may be passed on to third parties without our express written consent.

The Royal League



© ZIEHL-ABEGG SE - 00704871 - EN - MA - 10/2017 - 2.500 - Maurer - This catalogue contains information for your guidance. No guarantee is provided with regard to the accuracy of all information and no legal claims may be derived from this. Reproduction of this information, or extracts thereof, is permitted only with written approval.